

Operations manual

Oliver™

Innovate. Build. Repeat.

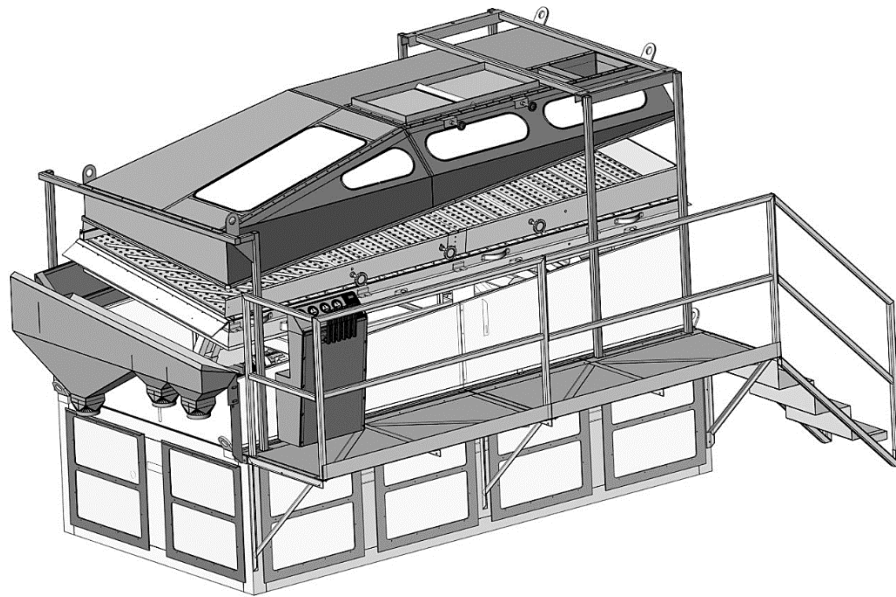

Maxi-Cap Series

Gravity Separators

Version 1.1 | 2/7/23

Table of Contents

Safety precautions	2
Important precautions for using the Maxi-Cap Gravity Separator	2
Operating instructions	3
Installation	3
Foundation requirements	3
Handling	4
Protecting the deck	4
Electrical Requirements	4
User-supplied motor installation and belt adjustments	5
Dust Hood Installation	6
Clean air source	7
How does a gravity separator work?	8
The process of stratification	8
Oliver Steele's rules for the use of gravity separators	11
What separators can and cannot do	11
Maxi-Cap Controls	12
Deck	12
Feeder	12
Aspirator feeder	13
Operational controls	13
End raise (slope)	14
Side tilt	14
Deck speed (eccentric speed)	15
Airflow	15
Startup and operation	17
Initial starting procedures	17

Maxi-Cap Gravity Separator

Separation procedures	18
Setup	18
Starting the Maxi-Cap.....	18
Adjusting the airflow	19
Adjusting the side tilt	20
Adjusting the deck speed.....	20
Adjusting the end raise	21
Increasing capacity	21
Removal of heavy foreign material	23
Product separation.....	23
Separation results.....	23
Troubleshooting	25
Introduction.....	25
Check these first.....	25
Blinded decks.....	25
Dirty air filters.....	25
Inadequate foundations.....	25
Operating at too much capacity.....	26
Improper dust hood arrangement.....	26
Using the wrong deck overcover	26
Belt slipping	26
Adjustments.....	26
End raise	27
Side tilt.....	28
Deck speed.....	29
Airflow	29
Feed rate	30
What to do with unsuitable products.....	31

Typical issues and how to solve them	31
Maintenance.....	33
Decks	33
Deck repair & replacement.....	34
Hydraulic system (side tilt and end raise only)	35
Bearings	36
Dust hood and air duct.....	36
Specifications.....	37
Air Requirements for each Maxi Cap Gravity Model.....	37
Aspirating feeder.....	37
Physical.....	37

Maxi-Cap Gravity Separator

Congratulations!

Dear valued customer, thank you for your purchase. Your Maxi-Cap Gravity is going to perform for you for years to come. At Oliver, we are here with you every step, starting with this operation manual. This manual will find new and valuable information both for experienced and inexperienced gravity operators need to know and understand.

Please allow adequate time to read, understand, and to become comfortable with the various Maxi-Cap operations. Taking the time now to learn how the Maxi-Cap works will help eliminate many of the problems frequently encountered.

Remember that the Oliver Gravity Separator is not a "cure-all" for the processor's problems. The gravity separator is a specialized piece of machinery designed to separate particles of similar size that differ in specific density.

Oliver Gravity Separators should not be used as a cleaning machine to remove dust, dirt, sticks, and other refuse frequently found in harvested crops or other materials. The gravity separator is not a sizing machine. Screening machines can do this more efficiently.

Safety precautions

Important precautions for using the Maxi-Cap Gravity Separator

- ▶ Always shut off and "lock-out" power when performing maintenance or service.
- ▶ Always ensure that the separator and components are electrically grounded.
- ▶ Always wear face and eye protection when inspecting or adjusting the separator.
- ▶ Never operate the separator with the air filters removed.
- ▶ Never operate the separator with the deck removed.
- ▶ Never operate the separator with missing or worn parts.
- ▶ Never operate the separator with the air chest boot removed.
- ▶ Never operate the separator with worn or damaged decks.
- ▶ Never use the deck as a table or workstation.
- ▶ Never stand on the separator.
- ▶ Always wear ear protection when operating the separator.
- ▶ Always keep separator clean and properly adjusted.
- ▶ Periodically inspect the separator for wear and correct operation.

Operating instructions

Important information about the operating instructions

This operations manual covers all Oliver Maxi-Cap Series of Gravity Separators. Instructions vary and require you to reference your specific machine layout drawings and parts manual. The two models are 3600 (4 fans) and 4800 (5 fans). The length of the deck is proportional to the number of fans.

The Maxi-Cap Gravity Separator is a specialized piece of processing equipment designed to separate particles that are similar in size and shape but differ in weight. These particles include sticks, stems, insect damage, shriveled seed, weeds, stones, and other rejected materials for agricultural, mining, recycling, food, and other products.

Some find that gravity separators benefit recycling, mineral concentration, plastic separation, and other industrial applications. The Maxi-Cap delivers its best results when used as an integral part of a processing line after the product has been thoroughly pre-cleaned and sized.

Installation

Installation is the beginning of a successful lifespan for your Oliver Maxi Cap. All Maxi-Cap Gravity Separators (hereafter referred to as just Maxi-Cap) are operated on test blocks at the factory for 30 hours to ensure that they ship to you in perfect operational condition. We inspect the drive train, hydraulic systems, and all controls during and after the operational period to ensure that they are operating correctly. If you run into any issues during the installation process, please call our direct line (on the cover page).

Foundation requirements

A solid, level foundation is required and regarded as the single most crucial aspect of installation. Failure to properly level and secure your Maxi-Cap can result in mechanical system failures not covered under warranty. When installing, note the type of flooring to which you will mount the anchors. We recommend a six-inch concrete slab, though that floor depth is not essential. If your surface is uneven, the false vibrations from the flooring can disrupt the quality of separation and cause cracking over time, which could lead to major breaks within your machine's frame. Therefore, we strongly advise your gravity separator to be firmly attached to a level concrete surface to ensure the safety and proper operation of the Maxi-Cap. If you plan on anchoring to another surface besides concrete, this surface should be enclosed on top to ensure cleanest air flow through the side filters. Any surface must be able to handle the static and dynamic loads of your machine. This information is provided in your machine's layout drawings. When securing your machine to the floor, it is recommended that you finger tighten the bolts or anchors, visually inspect for any gaps between the mainframe and the floor, fill those gaps using metal shims before fully tightening bolts or anchors. This will keep the machine structurally square, as built. Lastly, it is recommended that you apply a sealant between the bottom of the machine and the floor to ensure no dust or debris can be introduced to the fan

area of the machine. Please contact the factory to speak with an Oliver representative for the best installation recommendations. Lastly, when installing, be sure to leave adequate clearance around all sides of the machine. It is pertinent for your operator to possess sufficient space to access the machine while running your product. We recommend leaving the most available space around your Gravity table so you can adequately maintain your Maxi Cap when it is due for routine maintenance. Leaving adequate spacing will allow you to access and operate the controls quickly, open the electrical cabinet (if ordered), and remove the deck for changing or cleaning.

Handling

Your new Maxi-Cap Gravity Separator provides years of [maintenance](#)-free operation if handled properly. Most damage occurs during handling and installation. Please take extra care during installation not to cause damage, resulting in additional installation costs.

The Maxi-Cap Gravity Separator weighs between 6,000 and 10,000 pounds, depending on the model and accessories ordered with it. Be sure that the handling equipment is adequate for the load. While handling the machine, use appropriate lift lugs and take extra care not to damage the separating deck, the air filters, or any other machine parts.

Protecting the deck

The deck is the portion of the machine that contacts the product during separation. Take extra care not to damage it. During construction and installation, it is prevalent for contractors to use the deck's surface as a workspace or storage space for items they do not need. Please discourage this practice! The deck's design supports a relatively uniform product load over its entire surface. Storage of concentrated loads on the deck has resulted in bent or broken deck frames and damage to the wire overcovers. We recommend that a non-combustible surface, such as a sheet of 22-gage steel, be placed over the deck until the Maxi-Cap is ready to be used. Do not weld anything to the machine; doing so may damage the sensitive control electronics. If it is necessary to weld or cut above the machine during installation, take extra care to prevent damage from falling debris or sparks.

Electrical Requirements

Typically, motors will be installed at the factory and wired for 60 cycle, 220/440 volt, 3 phase, 1750 RPM unless otherwise specified on your order. The eccentric variable frequency drive (VFD) is voltage specific, so make sure it is correct for your voltage.

Proper direction of rotation is essential, and at least half of the problems with new gravity separators result from incorrect rotation. When your electrician wires the motor, be sure that he connects it so that it will run in the proper direction. The fan shaft, eccentric shaft, and blender shaft should turn counterclockwise when viewed from the discharge end of a left-hand machine, and clockwise on a right-hand machine.

Maxi-Cap Gravity Separator

User-supplied motor installation and belt adjustments

If you supply your motor(s), be sure that it is large enough to carry the loads for the gravity separator. Please refer to the User Supplied Motor Specifications listed below.

	3600	4800
Circuit size	208/230V 70 amps	208/230V 100 amps
	460V 35 amps	460V 50 amps

	Model 3600	Model 4800
Motor specifications (In HP)	FAN - 20	FAN - 25
	Deck – 2.0	Deck – 2.0
	Blender - 1	Blender - 1
	Pump - 0.5	Pump - 0.5

	Model 3600	Model 4800
Motor specifications (In KW)	FAN - 15	FAN - 19.5
	Deck – 1.5	Deck – 1.5
	Blender - .75	Blender - .75
	Pump - .37	Pump - .37

Our design provides bases for all motors. The factory supplies the hydraulic system motor, located at the bottom of the machine fan box, and the eccentric motor. The fan motor is at the machine's base below the feeder; the eccentric drive motor is inside the air chest, and the blender motor is directly under the blender.

While the motors are still outside the machine, install the motor shaft sheaves using the bushings provided. Place the motor on the mounting bracket, mount the belts, and align the motor by paralleling the DriveR sheave and the DriveN sheave. Adjust the belts to the proper tension and tighten the motor mounting bolts. After motor installation, check the belts for the proper tension. When belts are too tight, excessive strain is placed on the bearings,

shortening their lives. When belts are too loose, they will slip. Slippage will cause the belts and sheaves to overheat, shorten their life and result in poor performance of the machine.

First, to check for proper belt tension, turn off the machine and lock out the power supply. Next, apply pressure to the top of the belt midway between the sheaves. The belts should deflect approximately 1/2 inch. After the machine runs for 8 to 10 hours, recheck the belts. It is normal for new belts to stretch, so the tension will probably have to be adjusted.

Dust Hood Installation

** Note: Before installing the dust hood, ensure your mainframe is secured and fastened to a solid foundation.*

Oliver Maxi Cap Dust Hoods attach to the mainframe. You will connect the dust hood on four points of contact. The bolts for this installation are pre-screwed into the mounting points on all four corners. Unscrew, and set aside.

Accurate positioning is required for the hood to fit onto the machine properly. We recommend using a forklift to lift the dust hood up and 2-3 people to help with a guide and fasten. To make things easier, we numbered each corner to reference when installing.

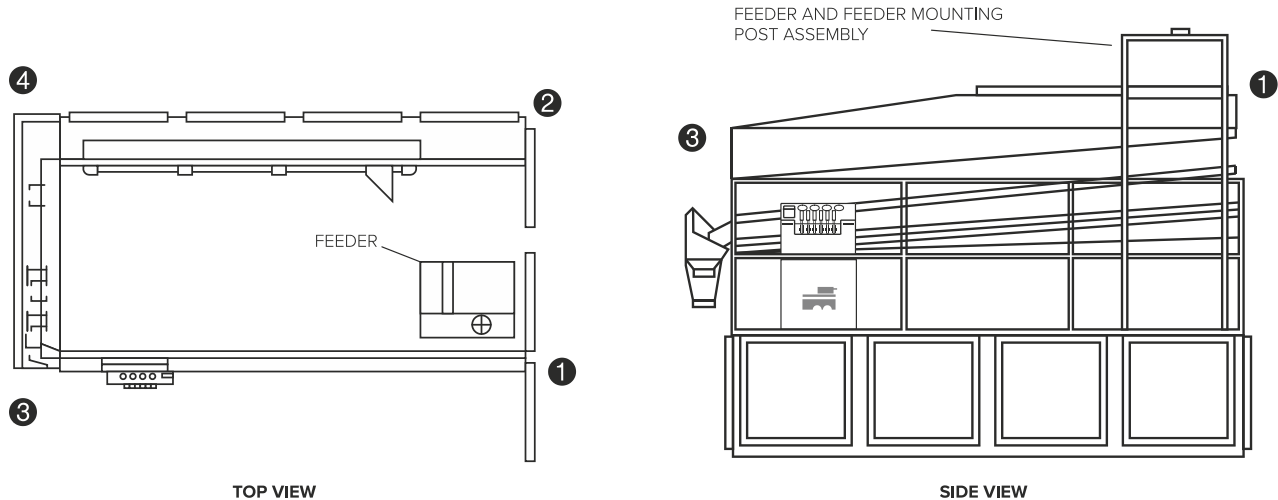

- ① The corner closest to the feeder
- ② The corner opposite the feeder on the feed end
- ③ The corner of the light side on the discharge end
- ④ The corner on the heavy side on the discharge end

Figure 1: Installation view

Maxi-Cap Gravity Separator

Step 1

- Unscrew the dust hood from the packaging skid
- Remove the hood from the skid
- Check that all holes are marked and drilled *before* placing them over the mainframe
- Make sure you match the mainframe's feeder end and the dust hood's feeder end

Step 2

- Ensure all the mounting holes match up
- Screw in the bolts you set aside earlier—there should be a total of 10 3/8" (9.5mm) bolts)

Step 3

- Check the air balance to ensure you are receiving a properly balanced system.

The most critical factor in operation is to balance the air between, what the gravity is producing and what the exhaust fan is venting. By running your product, you can see if there are areas of dust discharged. If that is the case, start by opening the air gauge control on the dust hood. The gate must remain open until no air discharges between the dust hood and the machine.

Clean air source

Oliver recommends using the cleanest air source possible. Often this means bringing in outside air rather than drawing in polluted plant air through the filters. We recommend that when bringing source air in from an external source, the air be brought into the Maxi-Cap from the bottom or through the filter openings nearest the feeder.

Ductwork should be tightly connected to the machine and run to a clean air source with as few bends or turns as possible. The clean air source should have a pre-filter with an open area not less than the area of the deck surface. Do not use ductwork that is too small. Refer to the specifications for duct and air requirements.

After you finish installing your Maxi-Cap, take the time to become familiar with the following operating instructions and the theory behind gravity separation.

How does a gravity separator work?

About 250 B.C., Archimedes discovered the law of specific gravity: "All bodies floating in or submerged in a liquid are buoyed up by force exactly equal to the weight of the liquid they displace." The specific gravity of a particle is the ratio of its density to some standard substance, the standard usually employed being water with a specific gravity of one (1). In water, particles having a specific gravity of less than one will float, and particles with a specific gravity greater than one will sink.

The term "Gravity Separator" is a contraction of the proper name "Specific Gravity Separator," a separator of particles differing in their specific gravities. All Gravity Separators use air as a weighing medium rather than water. Since air is lighter than water, the relative difference between particles of differing weights increases. For this reason, the Gravity Separator is a sensitive machine and can produce a precise separation when operated correctly.

The process of stratification

Before separating a product by weight, it must be fluidized and stratified vertically. On gravity separators, lighter particles are moved upward through the fluidized bed. Heavier particles sink downward. This action produces stratified layers with lighter particles in the upper layers and heavier particles in the lower layers. Stratification occurs by forcing air upward through the particle mixture so that the particles rise or fall by their weight relative to the airflow. Air becomes the fluidizing medium for the process of stratification.

Figure 2 Figure 3 Figure 4 represents a cross-section of the Gravity Separator directly over a fan. A heavy and light product particle mixture fills the screen deck; the fan is off. In **Figure 3**, the fan is now "on," and airflow is adjusted. Notice that the heaviest particles sink to the deck's surface, and the lightest particles rise to the top, free of the deck surface. Proper regulation of the airflow is critical, or the result is a situation seen in **Figure 4**, where all particles are lifted free of the deck surface by the excess air. This process results in a boiling turbulent action and can re-mix the stratified product.

Principals of stratification

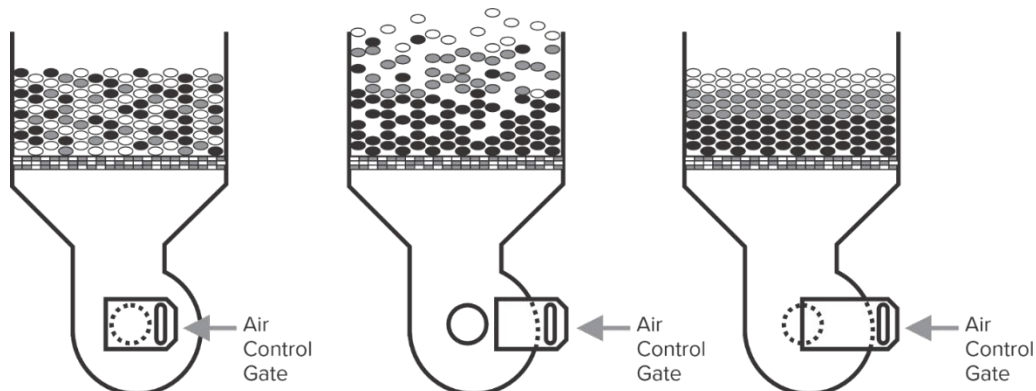

Maxi-Cap Gravity Separator

Figure 2

Figure 3

Figure 4

A particle mixture, illustrated in Figures 2, 3, and 4, falls from the feeder onto the deck. The area immediately around the feeder is called the STRATIFYING AREA. In this area, the vibration of the deck and the fluidizing action combine to stratify the product into layers. Heavier layers reside on the bottom, and lighter layers lift to the top (Figure 3). Separation cannot occur until the product becomes stratified. The size of the stratification will depend on the difficulty of separation and the processing capacity of the product. At no time should the stratification area exceed one-third of the deck surface.

The more complex the separation, the more area required to obtain proper stratification increases. For example, the stratification area is large when separating frosted beans from saleable beans because there is relatively little difference in weight. However, the stratification area is small when removing insect-damaged peas from whole peas because there is a significant difference in weight. Higher capacities likewise require larger deck areas for stratification.

Once the product is adequately stratified, the vibrating action of the deck begins pushing the heavier layers, in contact with the deck surface, toward the high side of the deck. At the same time, the lighter layers, which are at the top of the bed and do not touch the vibrating deck, float downhill toward the low side of the deck. As the product flows laterally from the feed end to the discharge end of the deck, the vibrating action gradually converts the vertically stratified layers to a horizontally graded bed of product.

Initially stratified into the upper layers, the lighter product floats downhill to the deck's light (low) side. Initially stratified into the lower layers, the heavier product is conveyed uphill toward the deck's heavy (high) side. When the product reaches the discharge end of the deck, the separation should be complete. Heavier products concentrate along the high side of the deck. Light products will be along the low side of the deck, and in between are intermediate products.

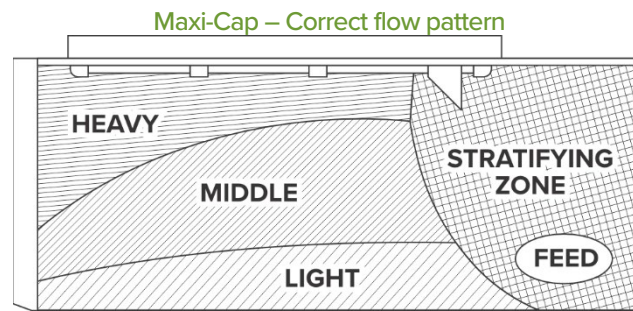

Figure 5

Figure 5 represents an ideal situation! While ideal situations are nice, they rarely occur in actual practice. Usually, the stratification area will not be clearly defined and must be assumed to occupy an area from 5 to 15 square feet around the feeder.

Figure 6 depicts the interaction between the three Forces of Separation: deck speed, airflow, and side tilt. The separation process begins immediately after the product becomes even partially stratified. Therefore, it is important to stratify the product as quickly as possible, or the lighter product may carry to the high side of the deck before the stratification process occurs. The best way to accomplish this is to use more air at the feed end than at the discharge end.

The discharge from the gravity separator is a continuously graded product ranging from the heaviest particle on the high side of the deck to the lightest particle along the low side of the deck. In many separations, the distinction between heavy particles and lighter particles is not visible to the unaided eye. In this case, periodic testing for weight per test volume (weight per bushel or cubic foot) at various points along the discharge would be necessary to determine if the process achieved the correct separation and desired results.

In practice, this continuous grade is usually broken down into three products; (1) a heavy or acceptable product, (2) a light or rejected product, or (3) a small middling product. In processing where rocks or other heavy trash might be present, a fourth product can be extracted, consisting primarily of dirt, rocks, or other heavy rejects.

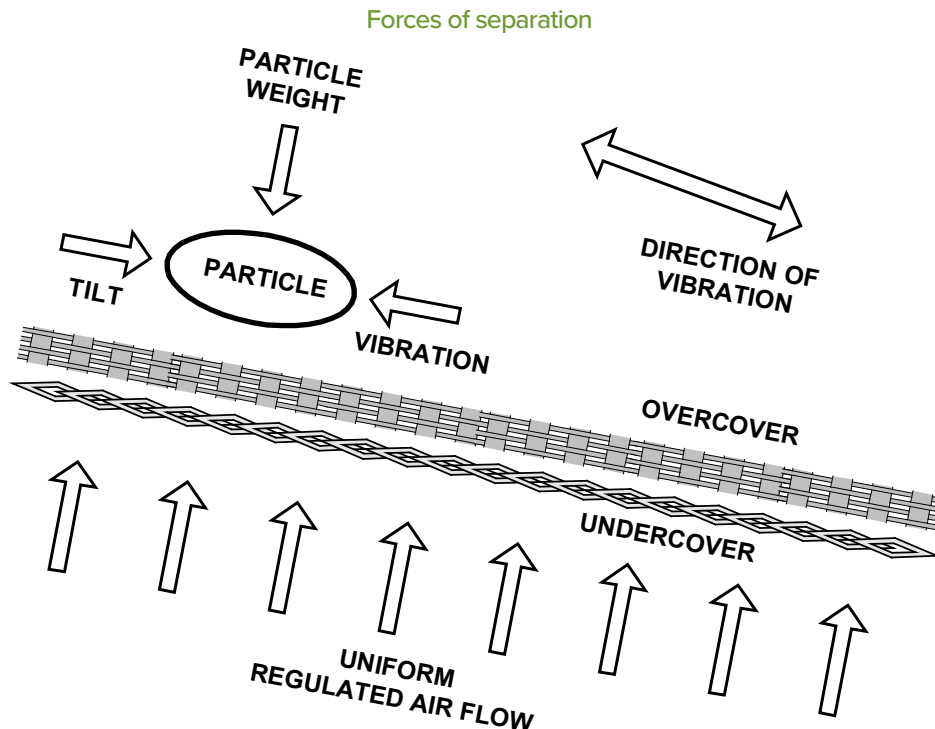
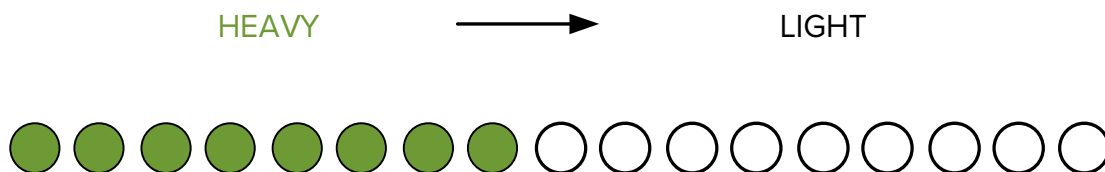

Figure 6

Oliver Steele's rules for the use of gravity separators.

What separators can and cannot do.

RULE 1 - particles of the same size but slightly differing specific gravities can be separated.



A typical example of this would be the separation of similar size seeds, the lighter of which has been hollowed out by the insect damage or lack of development.

RULE 2 - particles of the same specific gravities but differing in size grade according to the size of the particles.



A typical example of this would be the elimination of shriveled corn kernels from whole kernels of the same density.

RULE 3 - particles with different specific gravity and size cannot be separated efficiently.



An example of varying sizes and densities occurs on every ear of corn. Depending on its location on the ear, corn comes in various sizes, small rounds, medium rounds, small flats, medium flats, and large flats. Because of growing conditions, seed weight often varies within a given size range. The separation of unsized corn gives less than satisfactory results.

Maxi-Cap Controls

Deck

The most crucial part of any gravity separator is the deck because it is the main separating surface. The Maxi-Cap's deck consists of a welded aluminum frame, an application-specific undercover that develops the air pattern, and an application-specific screen or cloth overcover, which is the surface on which the product separation occurs. Two cutting fingers are installed on the discharge end of the deck. These are adjustable to channel different fractions of the finished product according to their density. Along the heavy product side of the deck are the cutout gates. These increase capacity, as described later in these instructions. The Rock Trap is on the same side of the deck as the gates but closer to the feed end. It bleeds heavy trash from the machine to avoid contamination of good heavy products. Knowledge of their locations is essential, as is understanding the controls that affect the variable adjustments of the Maxi-Cap operation. This topic is covered later in these instructions.

Feeder

Feeding is very critical to the operation of a gravity separator. The product should be fed uniformly with as few surges as possible. Surges, or variations of feed, will result in similar variations in quality. The Feed Control governs the amount of product fed onto the deck, [Figure 7](#).

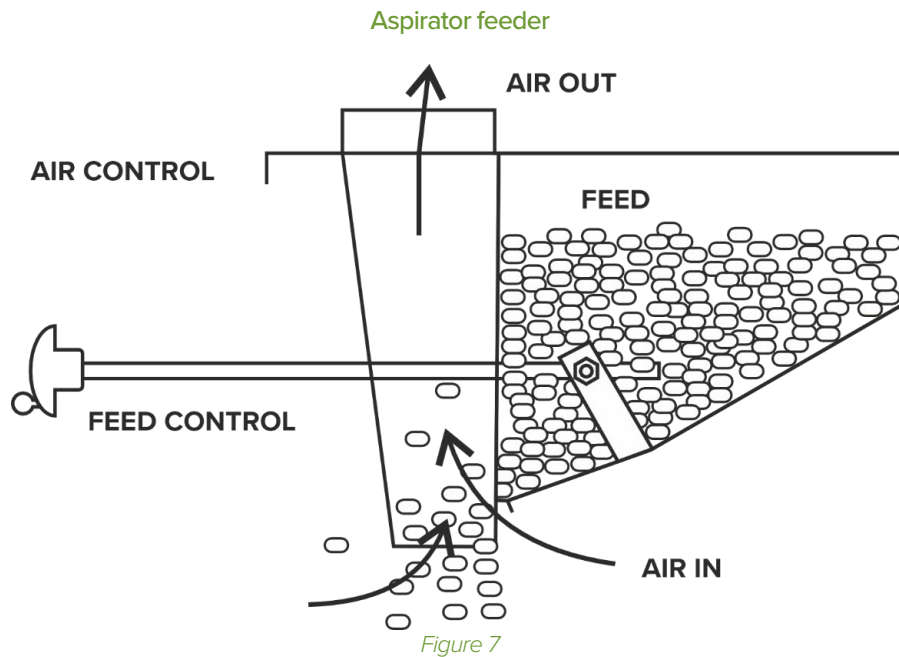

Generally, the feed rate determines the average capacity of the processing line equipment. The feed rate should be as low as possible for optimum separation without falling below the minimum feed rate, with the deck wholly covered. Typical minimum feed rates are not less than 60 percent of the rated capacity for your machine.

Maxi-Cap Gravity Separator

When starting your gravity separator, always start at a low feed rate. Adjust the gravity separator for best separation. Then increase the capacity to the desired rate. The maximum feed rate is when the product can be fed onto the deck and obtain the necessary separation.

Aspirator feeder

Unless it has a Dust Hood (optional), the Maxi-Cap comes equipped with an Aspirator Feeder, as shown on page [12](#). We designed the Aspirator Feeder to pre-clean dust, dirt, and fines from the product. As the product falls from the feeder to the deck, surface air is drawn through the product lifting the fine dust and trash. To control the airflow, open and close the damper located on top of the feeder. Set the feeder to pull as much air as possible without removing good product. Please refer to the specifications in the Maintenance Section for air exhaust requirements. Oliver can source and provide an appropriate air system if needed.

The feeder on the Maxi-Cap is opposite the discharge end on the low side of the machine. This placement provides the best stratification, separation, and operation at high capacity for most cereal grains and large seeds. However, it may be desirable to change the location slightly when operating at lower capacities on large-sized products or when working with small ones.

Operational controls

A Maxi-Cap has four major operational controls; end raise (slope), side tilt, deck speed (eccentric speed), and airflow. Control the end raise, side tilt, and airflow with the hydraulic valves located in a control console at the discharge end of the gravity separator,

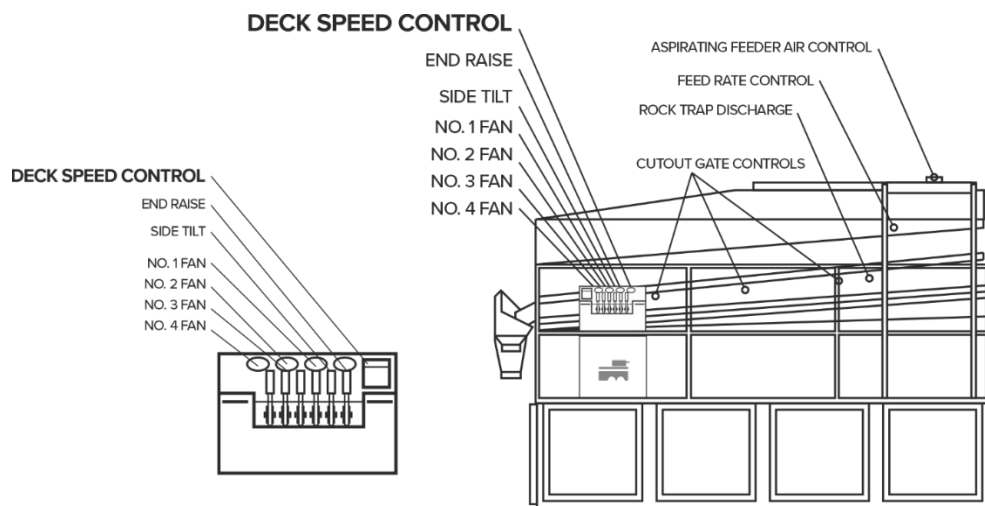

Figure 8

Figure 8. The control levers that operate the hydraulic valves are all "set up" to increase the control function as you push on the lever and decrease the control function as you pull on the lever. An electronic touch pad located on the control console controls the speed of the eccentric shake or deck speed.

End raise (slope)

The end raise is the slope from the feed end of the deck to the discharge end. The degree of slope determines the flow rate from the feed end to the discharge end. The slope and flow rate are directly related to the capacity, with a higher end raise delivering a greater flow rate and less exposure time for the product separation. Conversely, a lower end raise delivers a slower flow rate and more exposure time for the product separation. Quality of separation is directly related to exposure time for the product. The longer a product experiences exposure time, the higher the separation quality.

End Raise and feed rate are closely related controls. As the feed rate increases, so too must the end raise so that the depth of product on the deck will not become too thick. As the feed rate decreases, the end raise must also decrease. This adjustment ensures that the depth of the product will not become too thin, and the deck will remain completely covered. The end raise control lever [Figure 9](#) is located closest to the feed end of the machine. To increase the end raise, push on the lever. To decrease the end raise, pull on the lever.

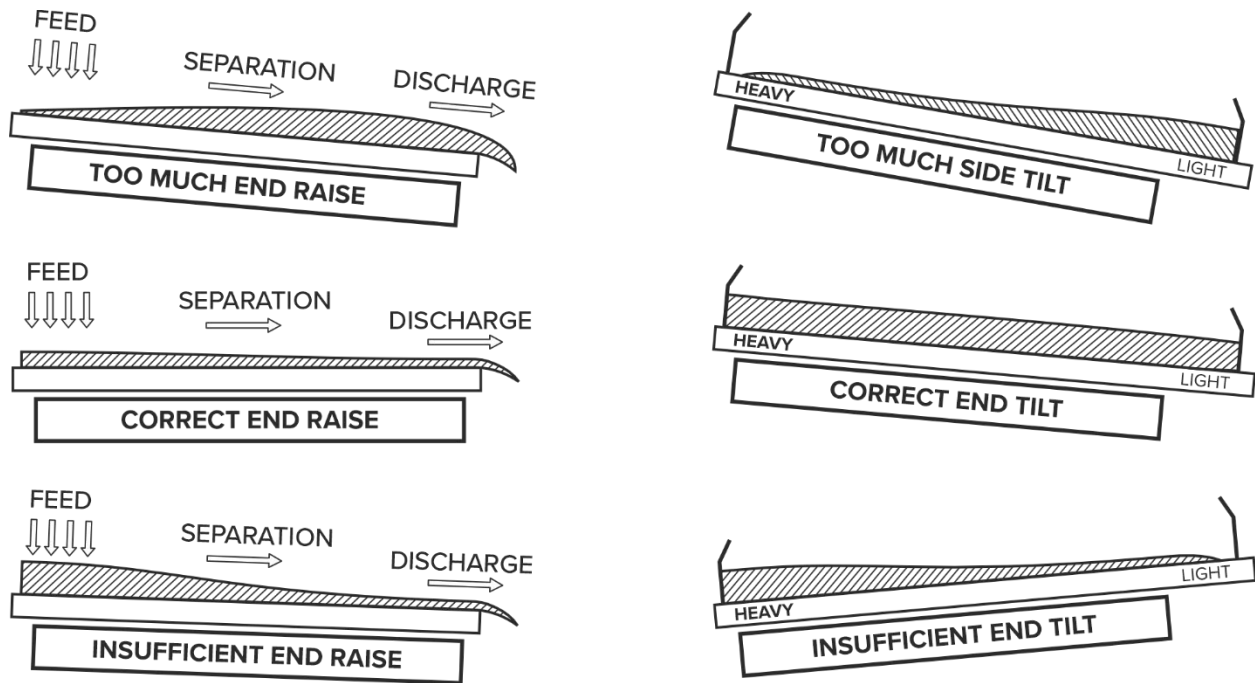

Figure 9

Side tilt

Side tilt is the difference in elevation between the high side of the deck and the low side of the deck. Increasing the side tilt will cause the product to shift toward the low side of the deck. Decreasing the side tilt will cause the product to shift toward the high side of the deck, [Figure 9](#). Typically, settings near or at maximum steepness deliver the best separation. However, take care not to set the side tilt too steep. A steep side tilt impedes product flow toward the

high side of the deck despite a high deck speed. Similarly, too slight a side tilt occurs when the product moves toward the heavy side of the deck despite a low deck speed.

The Side Tilt control is the second lever from the feed end of the machine, Figure 7 (see Page 13). To increase the Side Tilt, push on the lever. To decrease the Side Tilt, pull on the lever.

Deck speed (eccentric speed)

Deck speed and side tilt are closely related.

- Increasing the deck speed will cause the product to shift toward the high side of the deck.
- Decreasing deck speed will cause the product to shift toward the low side of the deck.

Generally, the product shifts toward the high side by increasing the deck speed. Increase the side tilt, and the lighter product shifts back toward the low side. This process delivers a more precise separation. Too much deck speed can be observed when the product shifts to the high side of the deck despite maximum Side Tilt being used. Deck Use the up and down buttons on the touchpad located on the control console. Use the touchpad to monitor the speed of the eccentric shaft. The optimal operating range is between 400 and 500 rpm.

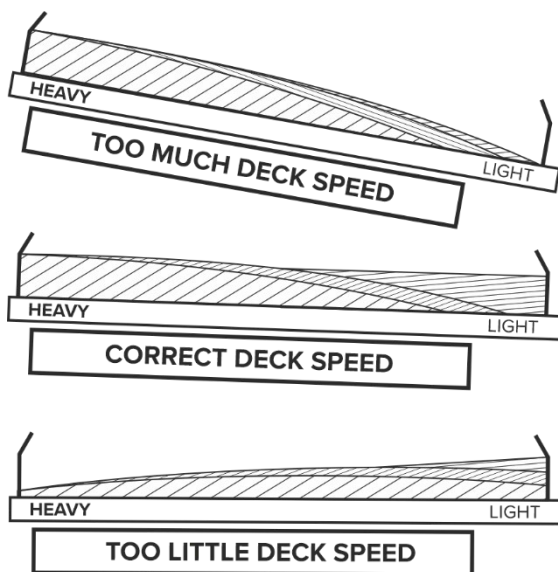

Figure 10: Deck speed.

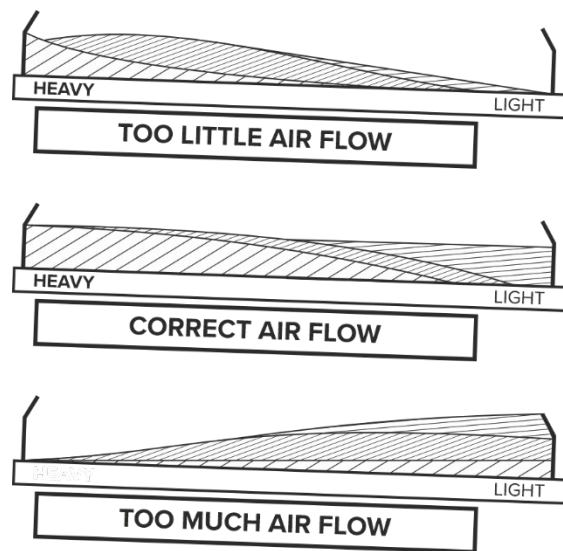

Figure 11: Airflow.

Airflow

Airflow control is one of the most critical adjustments on a gravity separator. Separation is not made by "blowing" the light product from the heavy product, but by controlling the airflow to create the stratified layers that are then separated through heavier product being in contact with the decks surface and by the deck speed. The most common airflow mistake is to use too much air in the separation process. Too little air will cause the product to

appear sluggish and pile up at the high side of the deck. Too much air will cause a boiling or bubbling action, lifting the heavier particles from the deck, and mixing them with the lighter top layers, [Figure 11](#).

With proper airflow control, the bed of the product will almost appear to be fluid. The product on the surface should be agitated and free flowing, except for the stratifying zone under the feeder. Bubbling should be kept to a minimum, allowing the vibrating deck to make the separation. We discovered, through experience, that the air pattern under the deck must be varied when working with different products and sometimes even within lots of the same product.

Each fan is individually adjustable by baffling the intake air to each fan zone to enable these corrections to be made quickly and accurately in the field, [Figure 12](#). This versatility enables the processor to adjust the air pattern and air volume to make an optimum separation. Your Maxi-Cap has multiple fans regulated by moving the air levers for each fan and corresponding fan zone under the deck. For more air (open the air gate), push on the lever. For less air (close the air gate), pull on the lever.

The #1 fan is located closest to the feeder. As the product flows down the deck toward the discharge end, it passes over each succeeding fan. Airflow must be adjusted in the area above each fan for best separation within that area. All the controls on a gravity separator serve a purpose and must be balanced with the other controls to obtain an optimum separation. With this understanding, you are now ready to begin making an actual separation.

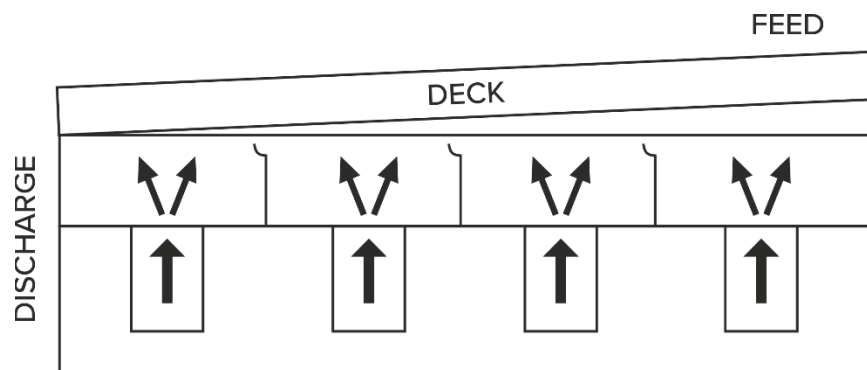

Figure 12: Model 3600 shown. Models 2400 and 3000 have three independently adjustable fans, and Model 4800 has five.

Startup and operation

Either levers or the electronic touchpad on the control console operates all Maxi-Cap operations (except feeder control, cutout gates, and rock trap). These controls require a consistent supply of power.

Initial starting procedures

Most adjustments take place as soon as the product is on the deck. Therefore, it is a good idea to operate the separator empty for a few minutes before attempting to make a separation. During this period, listen to the machine to become familiar with how it sounds during operation.

- Using the electronic keypad, change the Deck Speed to make the deck oscillate faster or slower. Locate the Side Tilt control (the second lever from the feed end of the machine). To increase the Side Tilt, push on the lever. To decrease the Side Tilt, pull on the lever.
- Remember that Side Tilt and Deck Speed must be balanced against each other to create a smooth, uniform bed of material across the deck.
- Check the feeding mechanism to ensure that you can control the feed rate. Turn the feed gate control clockwise to increase or counterclockwise to decrease the feed rate.
- Locate the end raise control (the closest lever to the feed end of the machine). To increase the end raise, push on the lever. To decrease the end raise, pull on the lever. Remember that both the end raise and feed rate balance against each other to ensure a uniform flow rate of material from the feed end of the deck to the discharge.
- Open and close the air gate for each fan. Pushing the lever opens the gate, and pulling the lever closes the gate. Airflow changes on an empty deck aren't observable, so although this does not produce a visible effect on an empty deck, hold your hand over the deck as fan speed changes. The airflow settings are an essential part of successful gravity separation.

Before turning off the separator, make one final check to ensure that the fan shaft is turning in the right direction.

When viewed from the discharge end of the machine, all shafts should rotate counterclockwise for the LEFT-HAND machine and clockwise for RIGHT-HAND.

Separation procedures

Setup

After becoming familiar with the operating characteristics of the Maxi-Cap, separation can begin. Close all Cutout Gates and the Rock Trap Gate on the high side of the deck. These settings increase capacity, and we will discuss them later. Preset the adjustments shown in [Table 1](#).

Model	Deck Mesh	Deck Slope	Side Tilt	Deck Speed	#1*	#2*	#3*	#4*	#5*
3600	8/10Ms	1/2	3/4	500	Full	3/4	1/2	1/4	
3600	12/16Ms	1/2	3/4	480	3/4	1/2	1/4	0	
3600	30Ms	1/4	1/2	460	1/2	1/4	1/4	0	
3600	60 Twill	1/4	1/2	480	1/4	1/4	1/4	0	
4800	8/10Ms	1/2	3/4	500	Full	Full	3/4	1/2	1/4
4800	12/16Ms	1/2	3/4	480	3/4	3/4	1/2	1/4	0
4800	30Ms	1/4	1/2	460	1/2	1/2	1/4	1/4	0
4800	60 Twill	1/4	1/2	480	1/4	1/4	1/4	1/4	0

*#1 fan is under feeder going down the deck to #5 fan at the discharge end.

Table 1: Preset adjustments

Starting the Maxi-Cap

Start the machine and make the initial preset adjustments based on Table 1 above according to the deck mesh of your machine at time of order. Open the feeder slightly and allow a thin product stream to flow onto the deck. After there is a small amount of product on the deck, adjust the deck speed so that product begins to flow toward the high side of the deck, [Figure 13](#) and [Figure 14](#).

Opening feeder

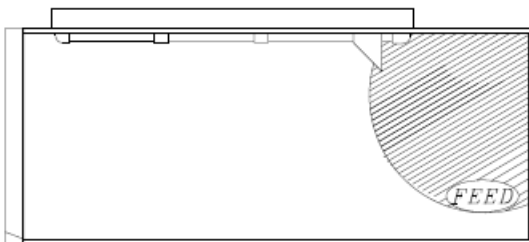

Figure 13

Filling the deck

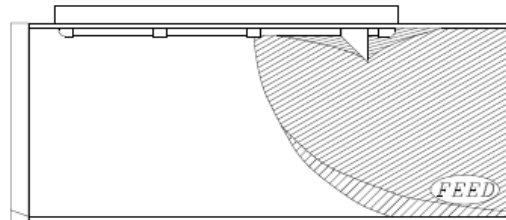

Figure 14

Adjusting the airflow

As soon as feed flows onto the deck, open the air gates for the #1 and #2 fans. As the deck fills, reduce the airflow on the first two fans to the Pre-set Adjustments listed in Table 1. Once the deck is completely covered, begin adjusting the remaining fans to balance the airflow. This action will allow maximum air at the feed end of the deck, which creates a bubbling, boiling action that causes the material to flow away from the feeder toward the light side of the deck, [Figure 15](#).

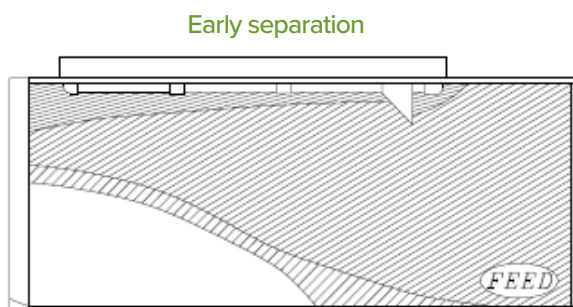

Figure 15

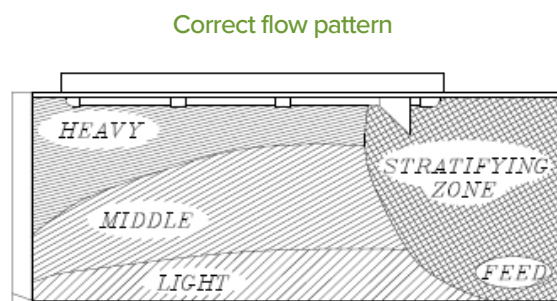

Figure 16

- Beginning with the fan at the discharge end of the deck, increase the airflow until you see a definite boiling, bubbling action.
- Reduce the airflow until the bubbling almost stops leaving the product bed in a fluid condition in the discharge zone over the fan.
- Move to the next towards the feeder and increase the airflow until you see a definite boiling action over the fan.
- Reduce the airflow in this zone until the product is fluid but not boiling. Continue this procedure with the remaining fans.
- After the final adjustment of the fan closest to the feed end of the deck, repeat the process with the other fans beginning with the fan closest to the discharge end. Work toward the feeder, one fan at a time.

Generally, by the time you have balanced the airflow twice, you will have a good pattern, [Figure 16](#). As you become more familiar with the machine and how the product flows, adjust the airflow in each zone as necessary, [Figure 17](#) and [Figure 18](#).

Too much air

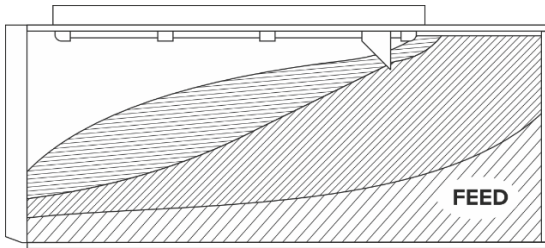

Figure 17

Too little air

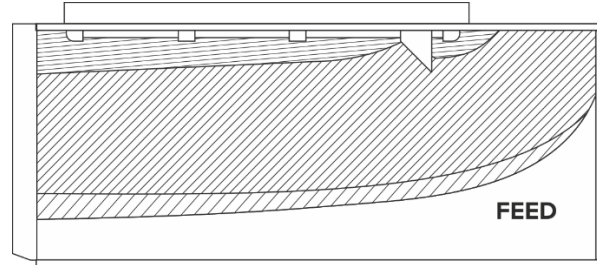

Figure 18

Adjusting the side tilt

Observe the depth of the product on the discharge end of the deck once there is a good airflow pattern. The product depth on the deck's high side should be 1 to 3 times as deep as on the low side (closest to the operator). If the product depth is too deep on the high side, increase the Side Tilt. If the product depth is too thin on the high side, reduce the side tilt, [Figure 19](#) and [Figure 20](#). The surface of the product should be smooth and uniform.

Too much side tilt

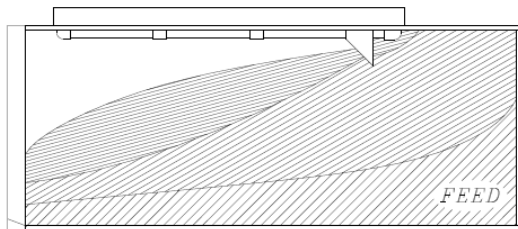

Figure 19

Too little side tilt

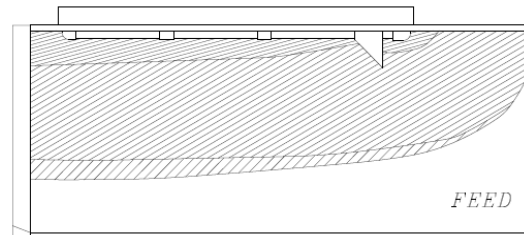

Figure 20

Adjusting the deck speed

Deck Speed serves two purposes in the correct operation of a gravity separator. First, it agitates the product to be fluidized entirely by the airflow. If the deck speed is too slow, the product will not be properly fluidized, resulting in no separation. If the Deck Speed is too fast, the product churns into a turbulent flow condition. This state results in too much agitation and will tend to re-mix the product producing poor separations

Second, Deck Speed is the separating factor for converting the vertically stratified product into a horizontally graded product. When operating within the range required for proper fluidization, increasing the Deck Speed moves the product toward the high side of the deck, and decreasing the Deck Speed moves the product toward the light side of the deck, [Figure 21](#) and [Figure 22](#).

Too much deck speed

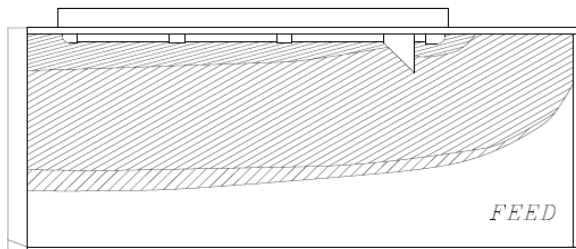

Figure 21

Too little deck speed

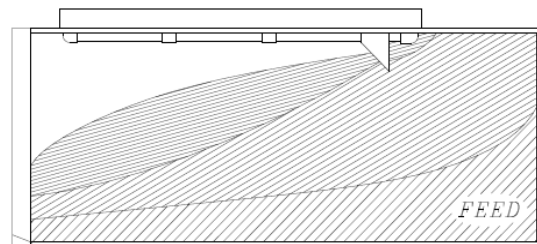

Figure 22

Adjusting the end raise

Check the End Raise of the Maxi-Cap. If it is correctly adjusted, the depth of the product at the feed end should be 1 to 3 times greater than that at the discharge end.

If the bed of material is too deep, increase the end raise by pushing the end Raise lever to cause the material to flow away from the feed end faster. If the material bed is too thin, decrease the End Raise by pulling on the end Raise lever to retain material at the feed end longer, [Figure 23](#) and [Figure 24](#).

Too much end raise

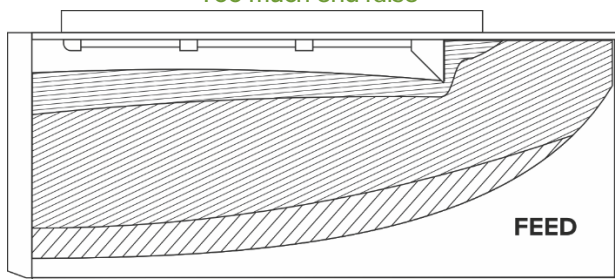

Figure 23

Too little end raise

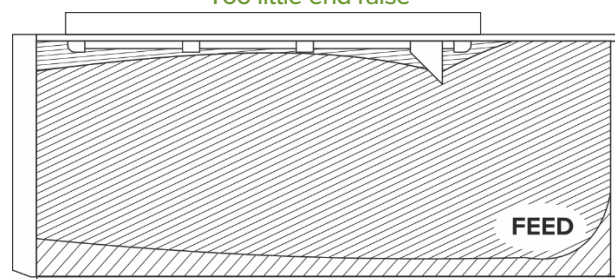

Figure 24

Increasing capacity

Once you achieve the desired separation quality, begin increasing the capacity. Open the feed gate slightly. This action increases the feed rate so that the bed depth will increase.

Observe the change in the product on the deck. You may need to increase the airflow slightly to compensate for the thicker bed of the product. Then increase the end raise (see the previous section) to compensate for the increased feed rate. Continue increasing the feed rate and end raise until the maximum feed rate, where the Maxi-Cap can maintain the required separation, has been reached. It is possible to increase capacity even more by opening the cutout gates along the high side of the deck.

Begin by opening the cutout gate closest to the discharge end of the Maxi-Cap. Turn the cutout gate knob clockwise and open the cutout gate until a small amount of product begins to discharge into the blender trough. You can increase the feed rate by a corresponding amount as you allow the product to discharge into the blender trough.

Generally, as you begin releasing more and more product from the deck into the blender, you will notice a change in the airflow pattern on the deck. After adjusting the cutout gates go through the airflow balancing procedure periodically. The number of open cutout gates determines the separation's difficulty and final quality. The easier the separation, the more cutout gates can be opened, and the higher the capacity obtained.

Always remember that capacity and quality offset one another. Therefore, if the separation quality does not meet the required standards, lower the capacity of the Maxi-Cap. Conversely, if the product is better than it needs to be, increase your operating capacity, [Figure 25](#).

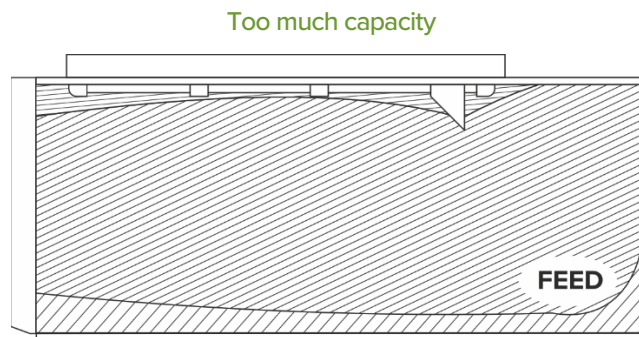

Figure 25

Another feature of the cutout gates is shifting the bed back and forth to accomplish different separations. You remove some heavier products from the deck by widening the cutout gates at a given capacity. This setting allows the lighter middle and light fractions to thin out and allows gravity to work more directly on the most challenging part of the separation, [Figure 26](#) and [Figure 27](#).

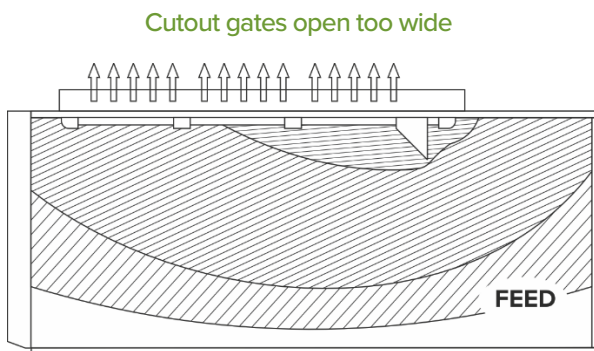

Figure 26

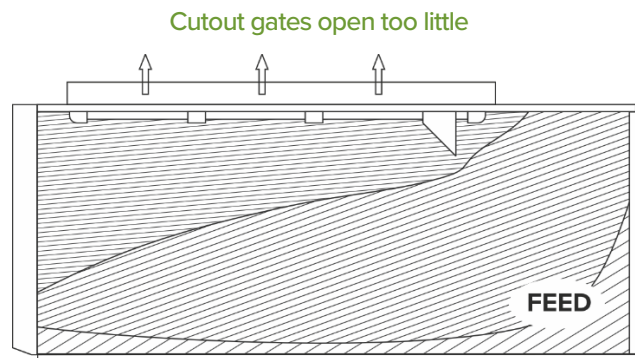

Figure 27

If the reject percentage is relatively small (less than 5%), the cutout gates should be opened reasonably wide, moving 20% to 50% of the product out the high side of the deck and into the blender trough. If the reject percentage is relatively high (greater than 5%), then the cutout gates should be almost closed, forcing the light product over to the low side of the deck more forcibly.

Removal of heavy foreign material

The rock trap is on the high side of the deck between the feeder and the first cutout gate. The rock trap's primary purpose is to remove a small percentage of heavy contaminants. The rock trap removes dirt and stones from edible dry beans or in other applications. The heavy contaminant may be removed from the rock trap. The more significant the density difference between the heavy contaminant and the good product, the easier the separation. Our rock trap has proven effective in many products and is a standard component in our equipment.

For best results, operate the rock trap to maintain a continuous discharge. If the concentration of heavy foreign product is low, adjust the rock trap gate at the minimum discharge rate you can maintain without bridging and stopping the discharge completely. Adjust the rock trap gate for a more significant discharge if a heavy foreign product percentage is high.

Product separation

At the discharge end of the deck are two cutting fingers. The cutting fingers have presets designed to produce a heavy, middle, and light fraction. Adjust the cutting fingers to handle any number of product fractions. The purpose of cutting fingers is to divide the product into the respective fractions. You decide where to divide your product since you know what you are trying to produce.

In a typical operation, the heavy fraction is a good product. The light fraction is a rejected product, and the middle fraction is a middle-quality product. However, in many operations, the middle of the light fraction is the desired product. Regardless of which fraction you wish to save; you decide on what to save and what to reject. Adjust the cutting fingers to produce a quality product that meets your standards. Check the results periodically to ensure that you produce the desired quality product.

Separation results

Many customers ask us to determine when they get the most from their gravity separator. This question is complicated because not all people want to accomplish the same thing. We manufacture Gravity Separators to make a separation based on specific density. First, the product must be cleaned and adequately sized to do this. The product's size, shape, and weight directly affect the separation. Classify the product according to size and shape before attempting to make a separation based on weight.

In an agricultural application, the fastest method of testing to determine the effectiveness of a Gravity Separation is through the use of a U.S. Standard Weight per Bushel Tester. Most industrial applications use weight per cubic foot

as a standard. Determine the difference in weight between the heavy and light product. Set the Gravity Separator to obtain the maximum weight difference between the light and heavy products.

This test gives a written record, for future reference, of the operation of the Gravity Separator and the settings necessary to obtain a separation of that product. Record the heavy, middle, and light fractions' test weight and the machine settings. For seed applications, germination and vigor testing use fractions, and the results recorded with the test weights.

Troubleshooting

Introduction

Even the most experienced operators run into problems that they cannot solve. Often times operators expect results too soon from their gravity separators. A certain amount of time is required for the entire deck surface to adjust to the new conditions. When you make an adjustment, please wait at one to five minutes before deciding whether it has made any improvement.

Please do not attempt to operate the Maxi-Cap Gravity Separator without understanding how and why it works. Your gravity separator makes a separation based on a particle's weight and its resistance to airflow. Proper adjustment of all the controls is necessary to obtain the best separation. The Maxi-Cap has four major quality adjustments: end raise, side tilt, deck speed, and airflow.

Check these first

Thanks to multiple conversations with customers, we have compiled a list of common issues most generally encountered after installation and found later after operation.

Blinded decks

If there is insufficient air and the fans are running correctly, clean the deck. Clean the deck by using compressed air to blow the dirt and chaff out from the top down into the deck while the gravity separator runs. See also [Cleaning Decks](#).

Dirty air filters

The air filters on the side of the Maxi-Cap screen dirt out of the air before it enters the machine. If these screens become plugged, the fans cannot pull enough air to provide proper separation—clean air filters by removing them from the machine and gently tapping them on the floor. Alternatively, achieve better results by removing the filters and using compressed air to blow out the dirt. If you must clean filters while the machine is running, use an industrial vacuum cleaner and vacuum the dirt from the filter surface.

Inadequate foundations

The Maxi-Cap is a counterbalanced machine. Still, it must be attached to a secure foundation. The foundation is probably too weak if you feel any vibration on the floor while the machine is running. Weak foundations lower the separation quality because the foundation absorbs some of the oscillating action intended for separation. Call the factory if you feel that you have an installation problem.

Operating at too much capacity

Often, slightly lowering the operating capacity will significantly improve the separation. Be careful not to decrease capacity too much. The machine's deck should be covered entirely. Capacity is usually dependent on the standards to be met and the quality of the product. Quality and capacity are inversely related. Increasing capacity usually lowers quality, while decreasing capacity usually improves quality.

Improper dust hood arrangement

Dust hoods reduce dust and dirt emissions into the plant and reduce noise levels. We have designed the dust hood and exhaust system to exhaust at least 5% more air than the machine uses for separation. Also, adequate make-up air must be available. Dust hoods and the associated air exhaust system design require expert knowledge to provide an economical and efficient system. If you equip your machine with a dust hood and feel that you are not getting proper separations, we suggest you contact the factory.

Using the wrong deck overcover

The Deck Cover is the portion of the machine that makes the separation. Without friction between the deck cover and the product to be separated, no separation will result. Therefore, select a cover that performs well with a specific product. Using the wrong cover will cause poor quality separation and insufficient capacity. Sometimes, an improper cover will cause sufficient damage to the deck that may require a rebuild. Generally, the cover should have a rough surface texture, and the openings should be as large as possible without allowing the product to fall through. Oliver offers standard decks: cloth for small grasses; 30-mesh wire for seeds the size of alfalfa and clovers; 16-mesh wire for seeds the size of wheat and oats; and a 10-mesh wire for large seeds, such as beans. A variety of special decks to meet needs are available. Contact the factory for further information.

Belt slipping

Belts commonly slip on new machinery. New belts tend to stretch slightly and should be checked frequently during the first couple of weeks of operation. Turn off the machine and lock out the power supply to check a belt. Then apply pressure to the back of the belt midway between the two pulleys. The belt should deflect approximately 1/2 inch.

Adjustments

Adjustments are a common problem with new, inexperienced operators. The solution is usually gaining more experience. Oliver can provide onsite training for your Operators as a service. If this is of interest, please contact the factory.

Do not be afraid to adjust the machine. Make an adjustment and wait one to five minutes to determine the effect and decide if it is good. Then try something else for further improvement. If the effect is insufficient, return to the original

Maxi-Cap Gravity Separator

setting. Finally, remember to make all adjustments in small increments. It is better to approach the final setting through several small steps than to make one adjustment that might be too large.

The final pattern on the deck may vary depending on the processed product. Depending on the size of the product, we suggest the following:

Product size	Average depth
Smaller than 1/32 inch in diameter.	Less than 1/4 inch.
1/32 to 3/32 inches in diameter.	1/4 to 1/2 inch.
1/16 to 3/16 inches in diameter.	1/2 to 1 inch.
1/8 to 3/8 inches in diameter.	1 to 2 inches.

As a general rule, the product depth along the high side of the machine should be from 1 to 3 times the depth along the low side. The average depth of product at the feed end of the machine should be from 2 to 4 times the average depth at the discharge end. These patterns will not be correct for all products. However, an approximation of these conditions on the deck surface will provide an initial setup. From this point, make the necessary adjustments to obtain an optimum separation. As an additional aid in making your adjustments, we provide a chart that shows many situations that can occur and lists adjustments that will help correct the pattern, [Figure 32](#).

End raise

End raise determines the rate at which the product flows from the feed end of the deck toward the discharge end. High feed rates require a high-end raise setting, and lower feed rates require lower settings. End raise determines when to expose a product to the separating action. Therefore, the end raise directly affects the quality of separation. Usually, decreasing the end raise increases separation quality, [Figure 28](#).

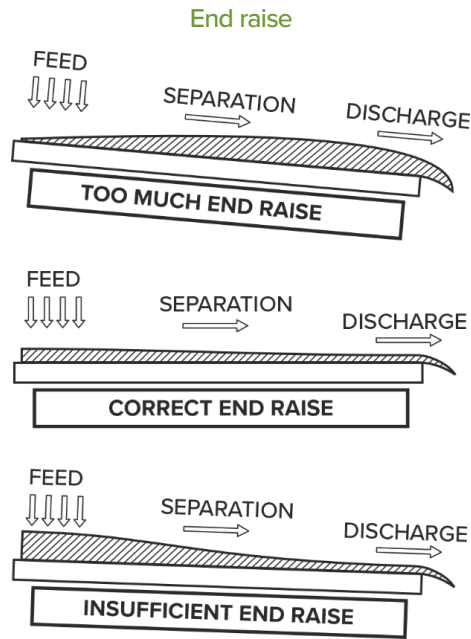

Figure 28

Side tilt

Side Tilt is the difference in elevation between the high side of the deck and the low side of the deck. Too much Side Tilt is present when the product cannot climb to the high side of the deck. Too slight a side tilt is present when the product will not float to the low side of the deck, [Figure 29](#). Typically, set the slide tilt at the maximum height to maintain an acceptable pattern across the deck.

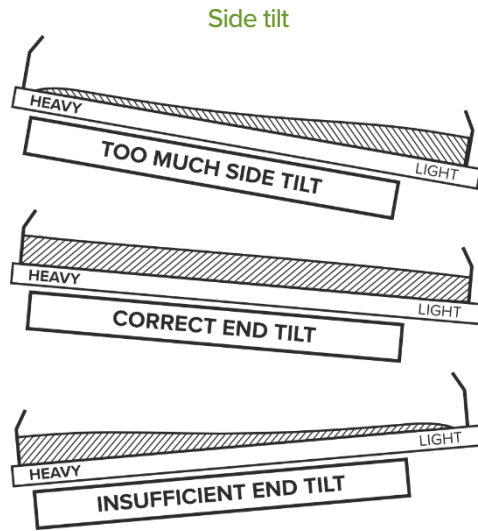

Figure 29

Deck speed

Deck Speed is the rate of vibration of the deck. The vibrations provide the agitation required so that product can be stratified, separating the heavier lower layers of the product from the lighter upper layers of the product. Deck speed and side tilt combine to get the best separation action. Too little Deck Speed will not agitate the product sufficiently to be adequately stratified. Too much Deck Speed will cause the product to flow to the high side of the deck and spill over the banking rail. Usually, with too little Deck Speed, the product will lay on the deck without moving, and the deck will quickly become overloaded [Figure 30](#).

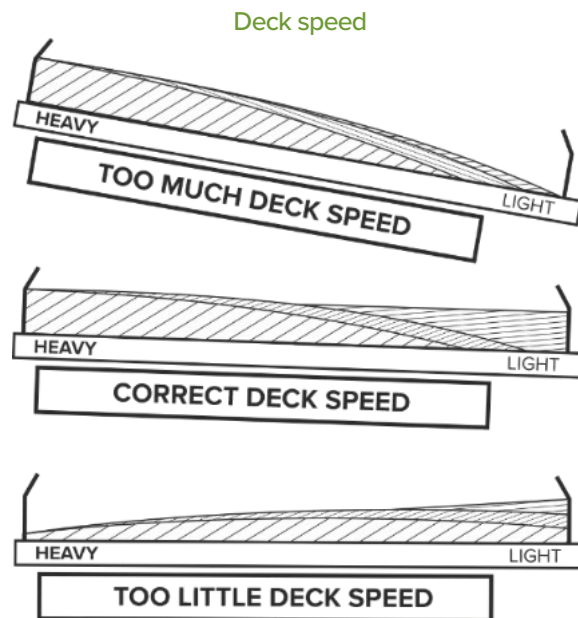

Figure 30

Note: An additional note, an overcover that is worn can also adversely affect product flow from low to high. If you have an older overcover and find that you have to keep reducing the side tilt or increasing the deck speed to drive good product to the high side, please evaluate the overcover on your deck. It may need to be replaced.

Airflow

Air is stratifying medium. Unless the product is stratified correctly, a quality separation is impossible. Too much airflow will cause a bubbling/boiling action that re-mixes the product as fast as it is stratified. Too little airflow will not stratify the product correctly. Generally, higher airflow is required in the feed area to obtain good stratification. As the product moves from the feed end to the discharge end, progressively less Airflow is required to maintain proper stratification, [Figure 31](#).

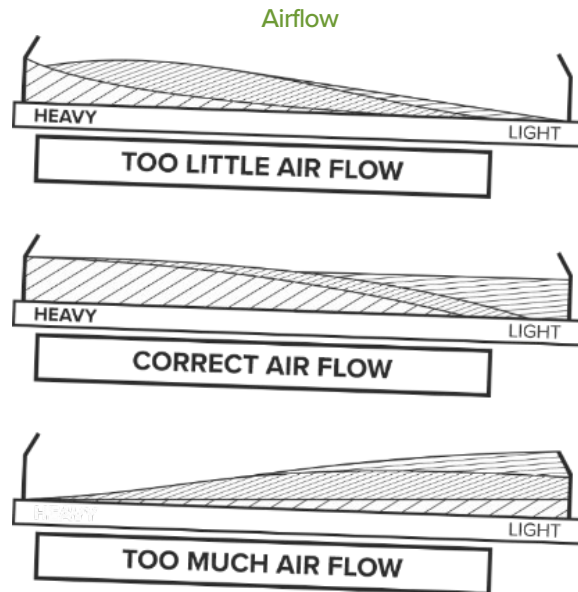

Figure 31

Feed rate

Feed Rate determines the capacity of the machine. We define the minimum feed rate as the lowest rate of feed at which an adequate cover of product spreads over the entire deck. Oppositely, the maximum feed is the highest rate of feed at which an acceptable quality separation is possible. Between these limits, separation quality generally goes down as capacity increases and up as capacity decreases.

What to do with unsuitable products

Typical issues and how to solve them

A product is rarely unsuitable for separation. Usually, a gravity separator will make some improvement in any free-flowing product. However, a gravity separator is a specialized machine designed to separate particles of varying densities and similar sizes. If the product does not fall into that classification, it probably cannot be separated on a gravity separator. Contact the factory in these situations, as we may be able to assist you with various solutions to ensure your product is similar in size with varying densities.

When making incremental adjustments, be patient and wait for your gravity to respond. The adjustments do not show on the gravity table instantly. See [Figure 32](#) for examples of improper adjustments.

Typical problems and how to solve them

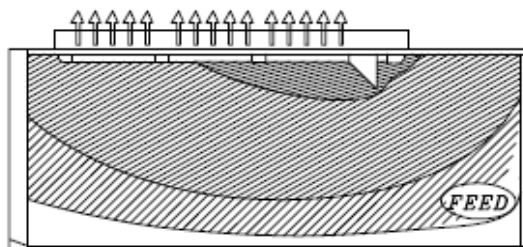

CUTOUT GATES OPEN TOO WIDE

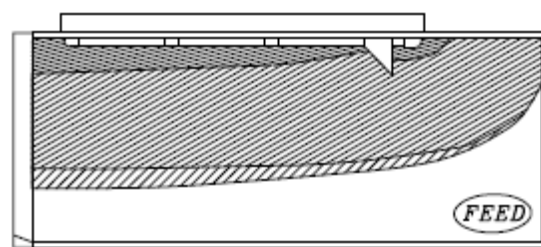

*TOO LITTLE SIDE TILT
TOO MUCH ECCENTRIC SPEED
TOO LITTLE AIR*

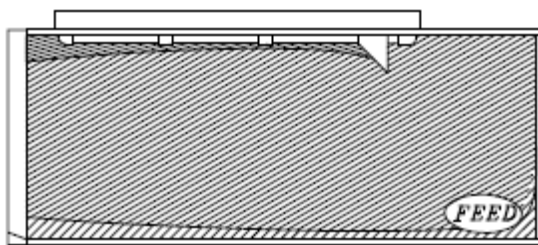

*TOO MUCH CAPACITY
INSUFFICIENT END RAISE*

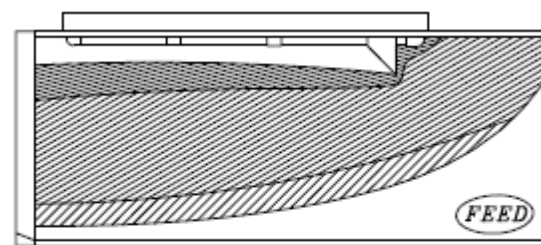

*TOO MUCH END RAISE
INSUFFICIENT CAPACITY*

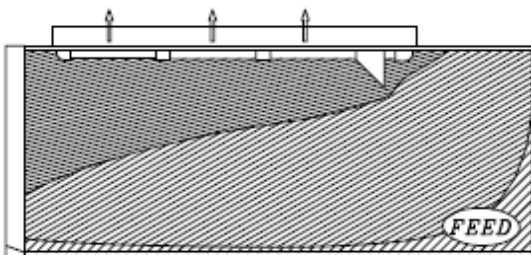

CUTOUT GATES OPEN TOO LITTLE

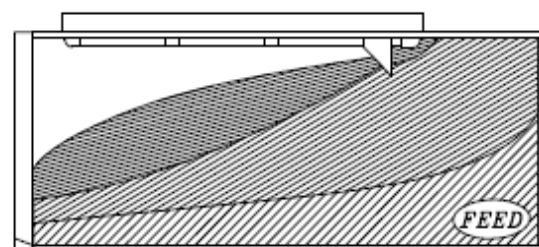

*TOO MUCH SIDE TILT
TOO LITTLE ECCENTRIC SPEED
TOO MUCH AIR*

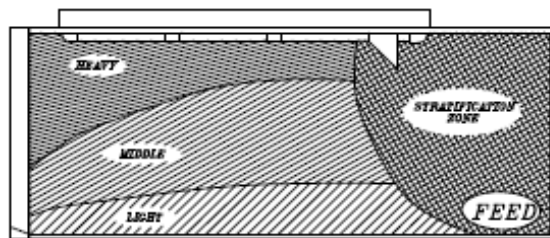

CORRECT FLOW PATTERN

Figure 32

Legend



Maintenance

Periodic maintenance is required to keep your Oliver Maxi Cap Gravity operating and running at its best. Depending on the product you run and how long you run product maintenance may need to be performed more frequently. The items listed below are recommended for regular routine maintenance:

Decks

The deck is the portion of the machine that contacts the product and makes the separation. Maintain optimal separation by frequently checking the deck and cleaning or repairing it. Even in very clean atmospheres, dust and dirt will build up on the underside of the deck. This buildup causes airflow restriction through the deck and will eventually plug the deck completely (blinded deck), [Figure 33](#).

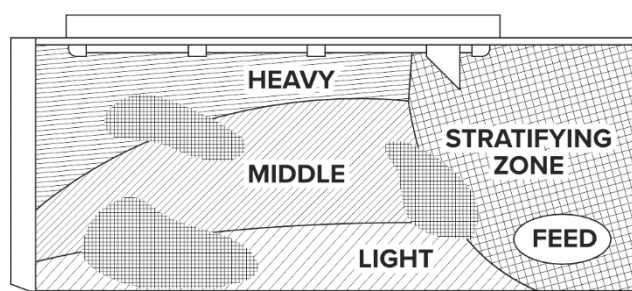

Figure 33

When the deck becomes plugged, it will be necessary to remove it from the machine and thoroughly clean it. A partially cleaned deck will become plugged sooner. To check if a deck is clean, place a light on a drop cord under the deck. If the deck is clean, you should be able to see the light through every opening of the deck cover. Contaminated areas will show dark spots and require additional cleaning.

Cleaning Decks

Cleaning a deck employs multiple techniques.

- **Try running the machine without products** for decks that aren't entirely clogged or run longer than usual on a given day. The fans will push out any unwanted dust or particles on top of the screen. (only available on Platinum-level machines).
- **It is not necessary to remove or handle the deck.** You can use a blow gun to clean the deck while in operation.
 - Sometimes with the fans running, the dust is pushed back up through the deck by the operational air and settles underneath the deck.

- Disadvantages are that the deck is not cleaned as thoroughly as when removed, and they must be cleaned more often.
- The fans push the dust through the deck.
- The dust does not settle inside the machine.
- For this purpose, we suggest a blow gun with an extended nozzle at least 48" in length. Air from the extended nozzle should be blown downward. With an extended nozzle you can clean the entire deck surface without leaning on the deck. We caution that you retain the OSHA blowing tip and install it on the modified cleaning wand to prevent any damage to your top screen.
- Lastly, if all else fails then resort to removing the deck entirely and take the time to thoroughly clean top and bottom of deck. You can do this using water or a blow gun. Be sure NOT to use abrasive or harsh chemicals when cleaning. Instead, power wash it or use alcohol.

Deck repair & replacement

Inspect your deck frequently for wear. Because decks are in direct contact with the product being, they are subjected to abrasive wear. As a deck wears out, the surface becomes smoother, and it becomes more and more challenging to move the heavier product out from under the lighter layers. Usually, when the wires of the deck overcover become worn, it is time to repair the deck. A wholly worn deck cover increases the danger of ruining the undercover, which develops the air pattern, [Figure 34](#).

New deck vs. worn deck comparison

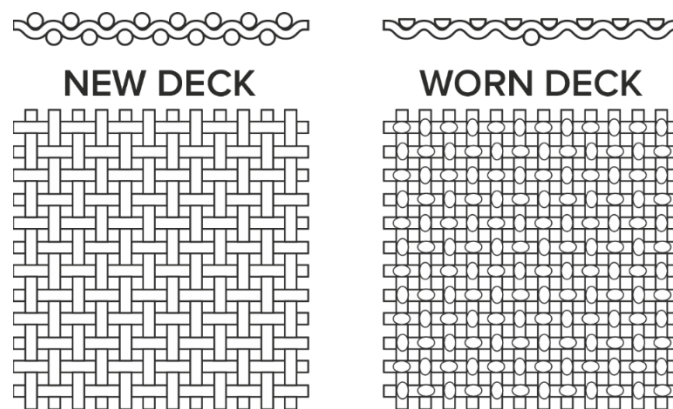

Figure 34

All decks with wire overcovers include a perforated metal undercover. These overcovers develop the air pattern, which makes the separation. If the undercover is not damaged, it is not necessary to replace it. When rebuilding a

deck, always inspect the deck thoroughly. Look at the underside of the deck and inspect each rib for cracks, dents, bends, or other problems. If the ribs are damaged, it will be necessary to tear down the deck completely to repair or replace them. Since the deck frame's construction includes high-quality aluminum, any repairs require someone experienced in working with aluminum. These repairs require in-factory attention.

We keep overcovers and undercover in stock. Should you need a replacement, you can order extra screens with our parts department and install them yourself or have one of our professionally trained staff replace them.

If you plan on a self-installation of your deck, please read the following:

When installing an overcover or undercover, it is best to place the deck on two sawhorses with a light underneath. By looking through the screen toward the light, you will easily be able to locate the ribs for fastening purposes. Always stretch the screen tightly. Tight screens give better separation results than loose ones.

Finally, inspect the deck trim, aprons, rails, and riffles; and replace what is needed. The horizontal metal pieces running across the top surface of the deck are called riffles. Riffles assist heavy particles in working uphill by trapping them behind the riffle and allowing light products to flow over. Riffles are riveted to the top of the wire overcover. The rivets should extend down into the deck ribs. If your deck has riffles, attach them over each aluminum rib precisely like the pattern supplied on the new machine.

Hydraulic system (side tilt and end raise only)

The Maxi-Cap uses a hydraulic system to make deck position adjustments and baffle the air for each fan zone. This system enables you to stand in one convenient place and quickly adjust the machine. Make all adjustments while the machine is operating, and ensure proper fluids and levels are maintained.

The fan chest houses the oil reservoir and hydraulic motor-pump assembly. Keep the oil reservoir maintained at the full level. If the reservoir requires a frequent filling, this indicates a leak. Leaks will allow air to get into the system and result in the Gravity Separator's erratic or poor operation. Locate and repair leaks as soon as they are suspected to ensure proper operation.

Oil and filters

The oil reservoir resides on the bottom frame of the machine opposite the control panel. Periodically check the oil reservoir to ensure it is "full." If the reservoir requires a frequent filling, check for leaks. We have designed the Maxi-Cap Series to operate efficiently for 24 months without the need to replace the hydraulic oil filter. When a new filter is required, order directly from Oliver Manufacturing.

Oil viscosity recommendations

You may use any major brand of anti-wear, non-detergent hydraulic oil, provided it meets the following viscosity requirements:

Temperature	SAE viscosity
-10 to 130 F	SW, 5W-20, 5W-30
0 F to 210 F	10W-30, 10W-40
Temperature	SAE viscosity
-10 to 130 F	22
0 F to 210 F	46

Purging Air from the System

Air in the hydraulic system will result in erratic operation of the hydraulics. If you suspect air in your system, you must purge the system. To purge the system, operate each hydraulic control through its entire range of operation for at least five complete cycles. Cycle each control periodically to ensure that air does not build up in the system. If you cannot purge the system by these methods, please call the factory.

Bearings

To prolong bearing life, grease with 1 to 2 shots at the start of each season or every 1000-1500. Sealed bearings are installed at the factory and will give better service if they are not over-greased. A bad bearing will generally be detected by a rumbling noise in the machine or by feeling an unusual vibration. Run the machine for at least 30 minutes to determine if a bearing is defective. Then, turn off the machine and lock out the power supply. Use a temperature gun to check the temperature of the bearing, if the temperature is more than 180F, you will need to change the bearing. Normal temp is 110-130F. Touch the bearing surface. If the bearing is excessively hot, replace it. You may have anywhere from 12 to 18 bearings located inside the machine.

Dust hood and air duct

Inspecting the feed control, air control, and rods inside the hood periodically for dirt buildup on the threads is recommended. Keep the inspection windows clean to enable the operator to observe the product on the deck.

Periodically check the ducting for settling of material in low places. Also, inspect the condition of the ducting. Look for cracks and leaks. Look for areas of deterioration where the material is wearing through the pipe. Repair these areas and change the deck layout to keep these problems from reoccurring.

Inspect the exhaust fan periodically. Look for unusual wear on the interior of the fan. Check the condition of the drive belts and shaft bearings to keep your dust collection system clean and in good working order. If you are using cyclones, be sure they are clean and functioning. Check the cone of the cyclone for obstructions. A plugged cyclone will adversely affect the whole system. A good maintenance program and clean equipment will go a long way to ensure a profitable and safe operation and prolong equipment life.

Specifications

Air Requirements for each Maxi Cap Gravity Model

Note: Air requirements vary with product size and density. Those listed below are the maximum airflows for the decks listed. For more specific information about your product, please call the factory.

Model	3600	4800
8/10-Mesh Deck:		
CFM's	25,000	30,000
Exhaust Air	25,000	30,000
12/16-Mesh Deck:		
CFM's	17,000	20,000
Exhaust Air	17,000	20,000
30-Mesh Deck:		
CFM's	12,000	15,000
Exhaust Air	12,000	15,000

Aspirating feeder

Model	3600	4800
All Decks:		
Exhaust Air	1,500	1,500

Physical

Model	3600	4800
Length (inches)	159"	194"

Width (inches)	109"	124"
Height (inches)	98"	102"
Weight (lbs.)	5800 lbs.	7600 lbs.
Deck Size (square feet)		
	60	90
Motors, HP (frame size)		
Blower	20(256T)	25 (284T)
Deck Speed	1.5(145T)	1.5 (145T)
Blender	1(143T)	1 (143T)
Hydraulics	0.5(56C)	0.5 (56C)



Parts, service, and training

One number solves it all.

Get the answers you need at 1 (719) 254-7813.

What can you get when you call 1 (719) 254-7813?

- Order replacement parts
- Schedule routine maintenance for your Oliver
- Get “refresher” training for new or existing employees
- Price quotations for updates, upgrades, or the latest Oliver machines
- Sample testing

Let our people help your people ▶



Oliver[™]
Innovate. Build. Repeat.

Feeling shy? Email our team at contactus@olivermanufacturing.com.

OliverTM

Innovate. Build. Repeat.

Oliver Manufacturing Company • 27151 Harris Road • La Junta, CO 81050 • (888) 254-7814

olivermanufacturing.com