

PLATINUM

Gravity Separators

- **Parts List – 4800 PL**

Oliver

Advancing the Science of Separation.

Main Office

17777 US Hwy 50
Rocky Ford, CO USA 81067

 Local: 719.254.7813

Fax: 719.254.6371

 Toll Free: 1.888.254.7813

 International: +1.719.254.7813

Production Unit

27151 Harris Road
La Junta, CO USA 81050

 Local: 719.383.9880

 Toll Free: 1.888.254.7813

General Sales Email: contactus@olivermanufacturing.com

Website: www.olivermanufacturing.com

PLEASE READ THIS BEFORE ORDERING PARTS

When you order parts we need the following information.

1. Your Name
2. Company Name
3. Shipping Address
4. Billing Address
5. Phone Number
6. Machine Model Number
(located on hydraulic control console)
7. Machine Order Number
(located on hydraulic control console)
8. Left Hand or Right Hand
9. Purchase Order Number
10. Parts Required
 - A. Part Number
 - B. Catalog Number
 - C. Drawing Number
 - D. Description
 - E. Quantity

Having the above information ready when you call will help to insure that we ship the right parts to you as quickly and efficiently as possible.

To determine the hand of your machine:

1. Stand on the discharge end of the machine facing the product as it is discharged off the deck.
2. On left hand machines the good product (heavy fraction) is discharged on the left side.
3. On right hand machines the good product (heavy fraction) is discharged on the right side.

A drawing showing both left and right hand machines is included with this parts list. Please use it as a reference.

Thank you for purchasing Oliver equipment. If you have problems or questions please feel free to call us any-time.

(719) 254-7813

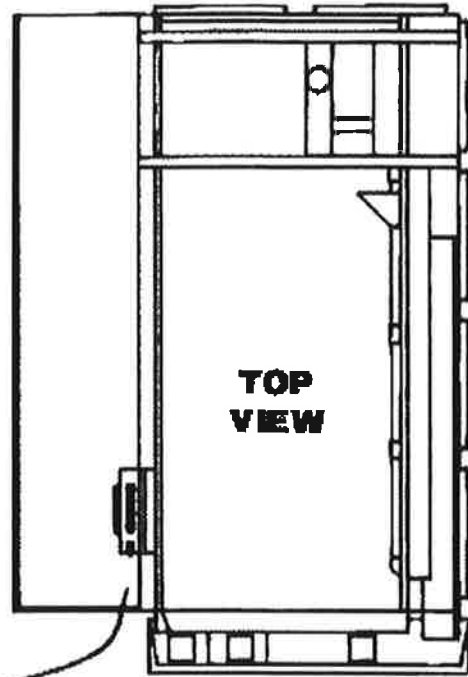
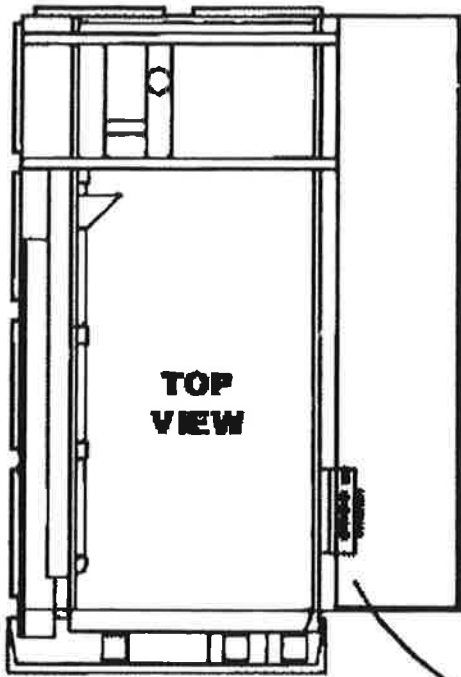

**MODEL NUMBER
ORDER NUMBER**

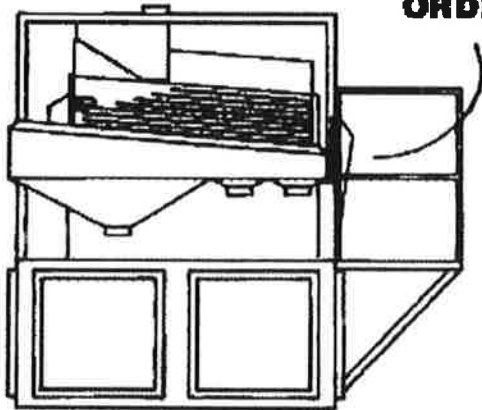

**DISCHARGE END
LEFT HAND**

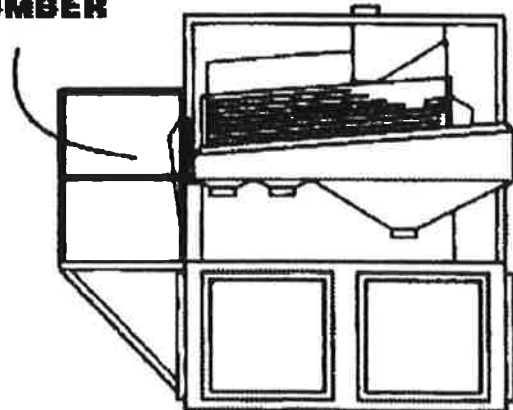

**DISCHARGE END
RIGHT HAND**

1. AIR FLUSH FILTER

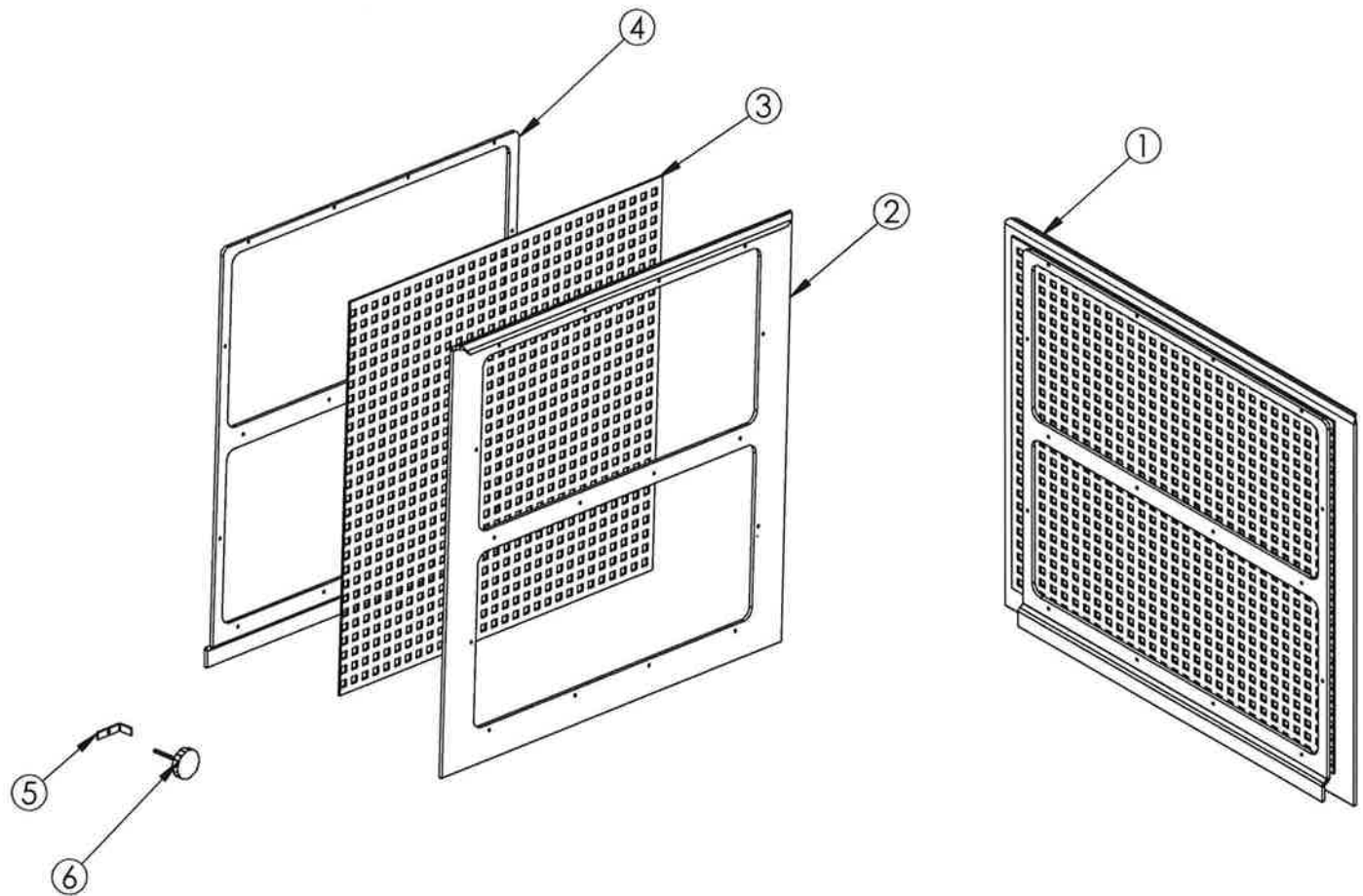

REF NO	DESCRIPTION	PART ID	QTY
1	M/C FLUSH FILTER COMPLETE	SAF003	14
2	M/C FLUSH FILTER FRONT PANEL	SAF225	14
3	M/C FILTER SCREEN 30 X 30 SS (FLUSH FILTER)	SAF226	14
4	M/C FLUSH FILTER INSIDE FRAME	SAF220	14
5	VOYAGER FILTER CLAMP	AAAAF1011000	28
6	STAR GRIP KNOB	ZFA350	28

2. BLOWER ASSEMBLY

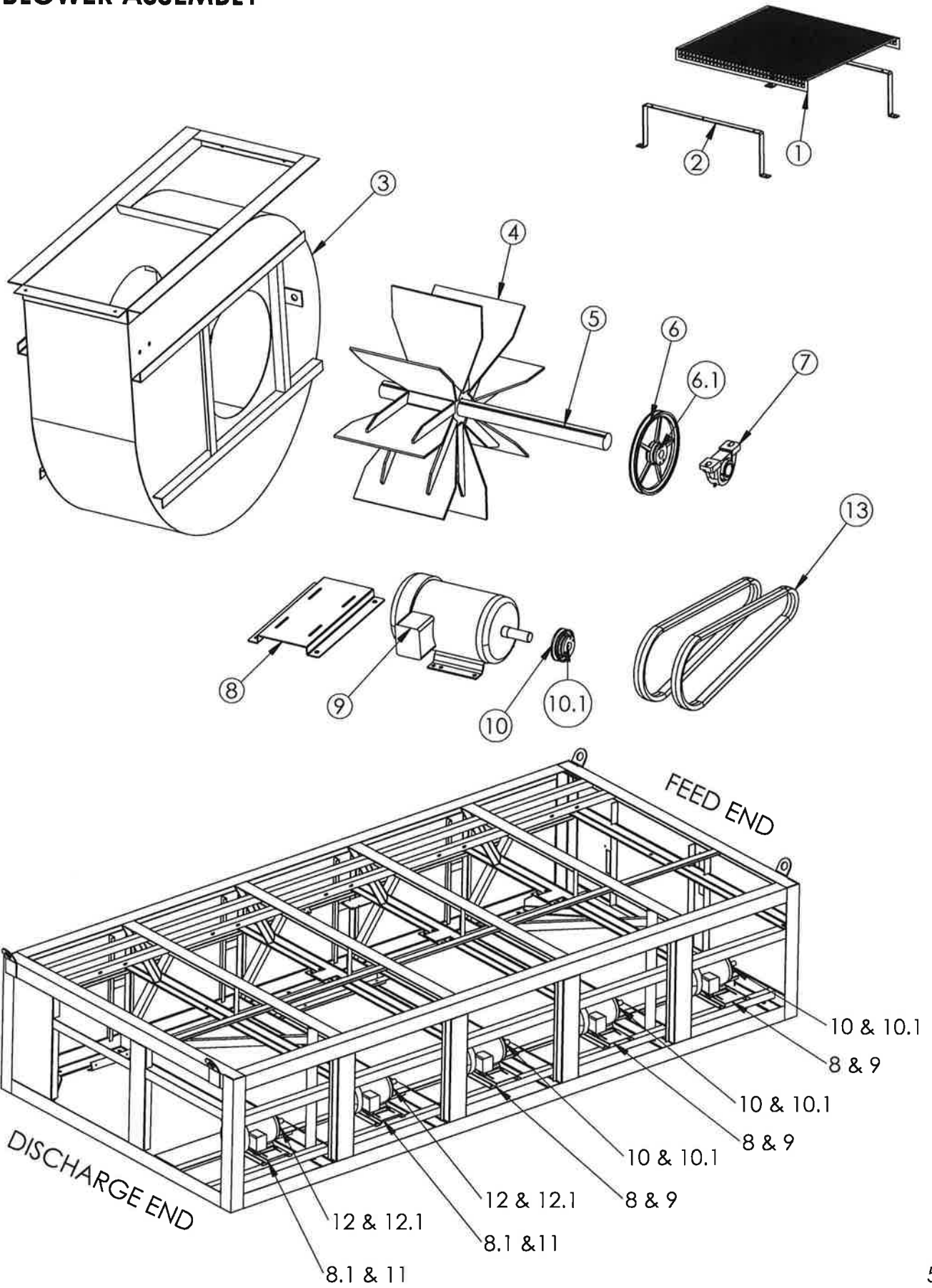

2. BLOWER ASSEMBLY

REF NO	DESCRIPTION	PART ID	QTY
1	AIR BAFFLE		
	18"	SBF503	(3)
	25"	SBF502	(2)
2	AIR BAFFLE BRACKET	SBF501	(10)
3	FAN DRUM -COMPLETE	SBF200	(5)
4	FAN WHEEL-COMPLETE	SBF100	(5)
5	PLATINUM FAN SHAFT R2	RBF120	(5)
6	2 GRV 5V 11.3 SK QD SHEAVE	ZBK920	(5)
6.1	SK BUSHING 2"	ZBK990	(5)
7	2" PILLOW BLOCK BEARING	ZBG220	(10)
8	METAL MOTOR BASE 213 FRAME	ZMT307	(3)
8.1	METAL MOTOR BASE 184 FRAME	ZMT307	(2)
9	7 1/2HP 230/460/3/60 213T TEFC E-MOTOR	ZMT109	(3)
10	2 GRV 5V 6.3SK QD SHEAVE	ZBK915	(3)
10.1	SK BUSHING 1 3/8"	ZBK984	(3)
11	5HP 230/460/3/60 184T TEFC E-MOTOR	ZMT104	(2)
12	2 GRV 5V 5.90 SDS QD SHEAVE	ZBK910	(2)
12.1	SDS BUSHING 1 1/8"	ZBK975	(2)
13	5V X 1000 BELT	ZBK205	(10)

3.SUSPENSION SYSTEM

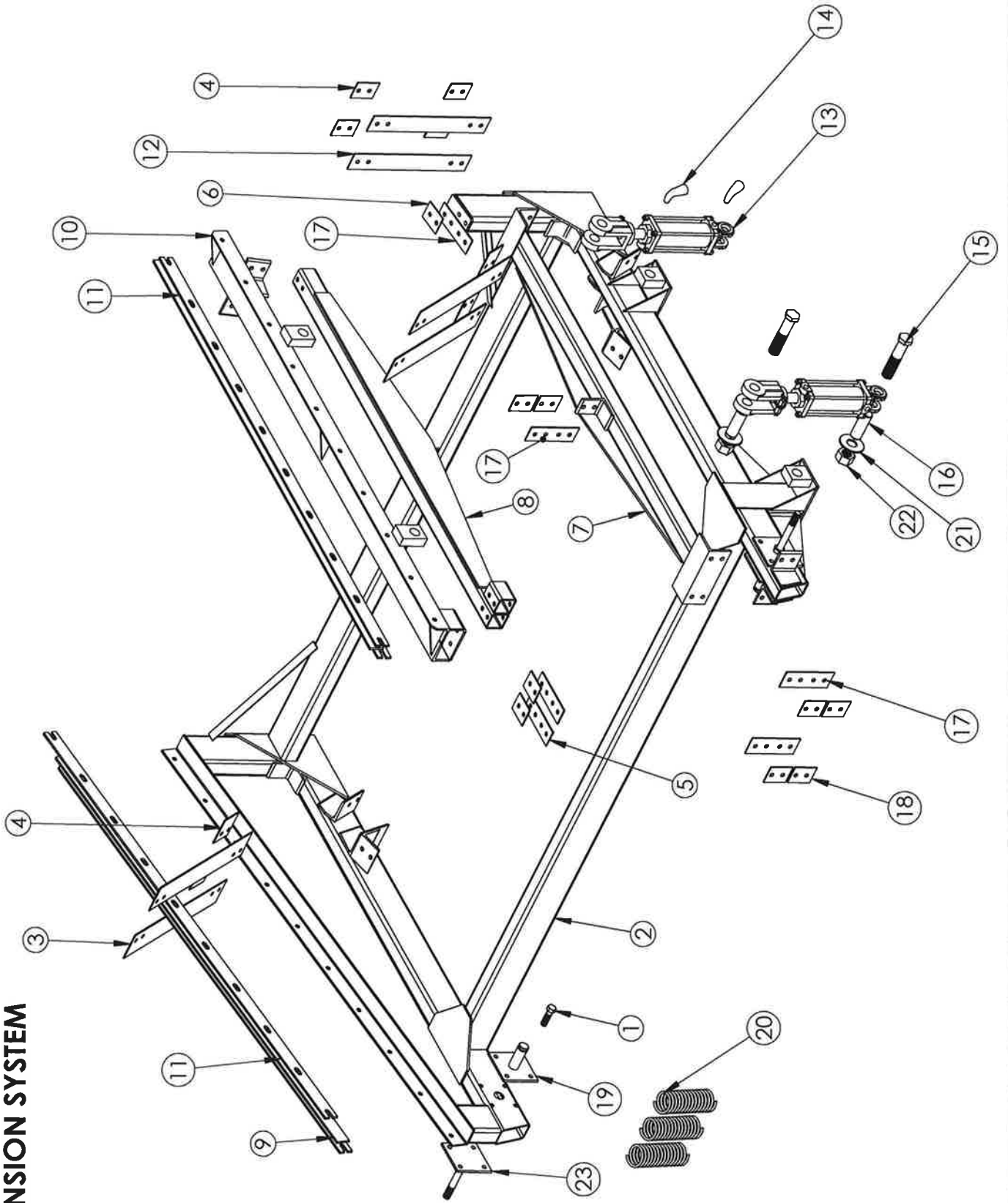

3. SUSPENSION SYSTEM

REF NO	DESCRIPTION	PART ID	QTY
1	5/8 X 4.5 HEX CAP SCREW	ZBT590	(16)
2	SPRING BOARD ASSEMBLY LH	RSB101	(1)
	SPRING BOARD ASSEMBLY RH	RSB102	(1)
3	SCOTCH PLY TOGGLE 2 X 16.5	ZFG110	(4)
4	SCOTCH PLY BACK PLATE 2 X 2.5	SSB101	(12)
5	SCOTCH PLY TOGGLE 1.75 X 5.5	ZFG135	(4)
6	SCOTCH PLY BACK PLATE 1.75 X 2.25	SSB102	(8)
7	SPRING BOARD STABILIZER LH	RSB211	(1)
	SPRING BOARD STABILIZER RH	RSB210	(1)
8	SPRING BOARD POWER TRANS.LINK LH	RSB221	(1)
	SPRING BOARD POWER TRANS.LINK RH	RSB220	(1)
9	SPRING BOARD MACHINE PLATE	RSB350	(2)
10	SPRING BOARD END RAISE LH	RSB301	(1)
	SPRING BOARD END RAISE RH	RSB302	(1)
11	HINGE PLATE BACKING STRIP	RSB351	(8)
12	SCOTCH PLY TOGGLE 2 X 13.5	ZFG120	(2)
13	HYDRAULIC CYLINDER 2 X 4	ZHY130	(2)
14	3/8" X 90 STREET ELBOW	ZHY281	(2)
15	5/8 X 4.5 HEX CAP SCREW	ZBT590	(12)
16	UHMW BUSHING	SHY342	(4)
17	SCOTCH PLY TOGGLE 2 X 5.5	ZFG130	(4)
18	SCOTCH PLY BACK PLTE 2 X 2.5	SSB102	(8)
19	SPRING BOARD TILT LINK MT	SSB105	(2)
20	EXTENSION SPRING 12 X 1.25	ZSB500	(6)
21	5/8 WASHER	ZWA940	(24)
22	5/8 JAM NUT	ZNT961	(12)
23	TILT SPRING MOUNT PLATE	SSB107	(2)

4.TILT CONTROL SYSTEM

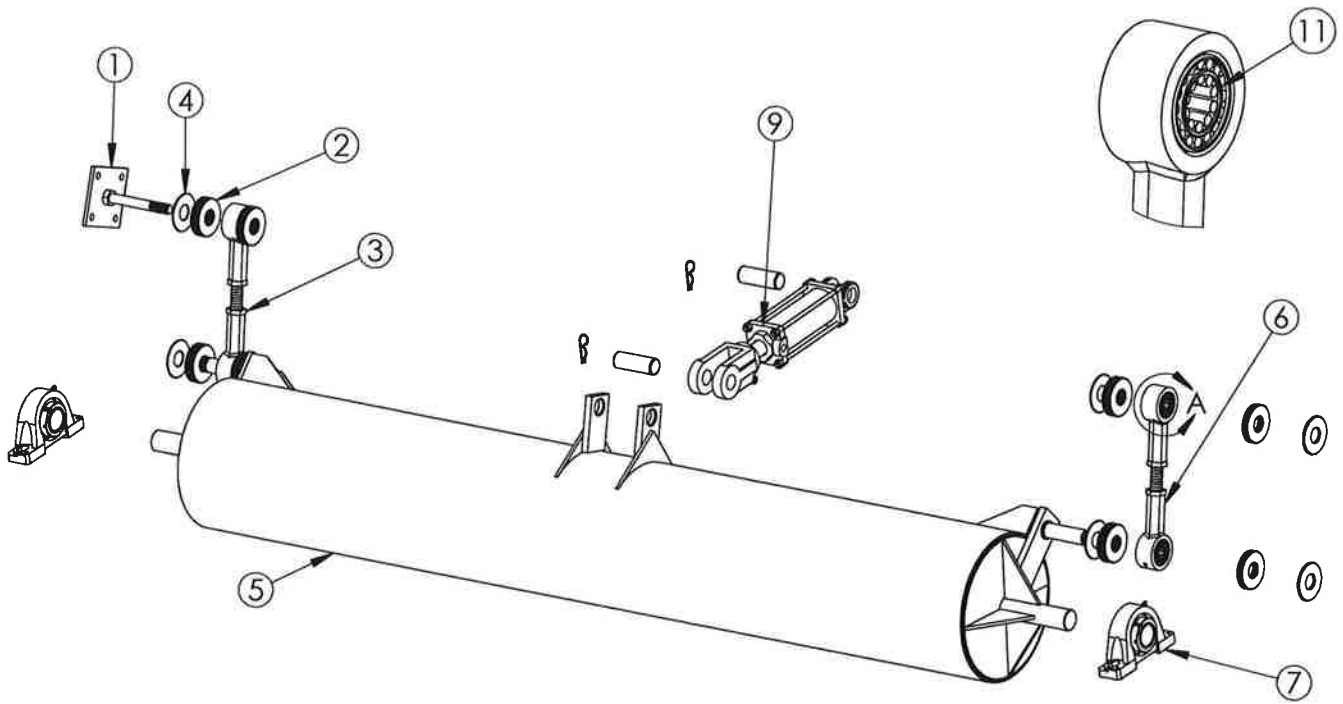

REF NO	DESCRIPTION	PART ID	QTY
1	SPRING BOARD TILT MT	SSB105	(2)
2	TILT BEARING PLASTIC WASHER	SEC306	(16)
3	3/4" NUT	ZNT971	(12)
4	1" FLAT WASHER	ZWA950	(14)
5	TILT TUBE 65 1/2"	REC201	(1)
6	TILT LINK COMPLETE	SEC310	(1)
7	1-7/16" PILLOW BLOCK BEARING	ZBG210	(2)
8	3/8" 90 STREET ELBOW	ZHY281	(6)
9	HYDRAULIC POSITION CYLINDER CYLINDER - 2 X 6	ZHY141	(1)
10	ECCENTRIC BEARING BKT TILT/SPEED CY. MT (OLD PART NOT SHOWN)	SEC150	(1)
11	1" INNER BEARING W/RACE - MI- 16	ZBG250	(4)

5. DECK ASSEMBLY

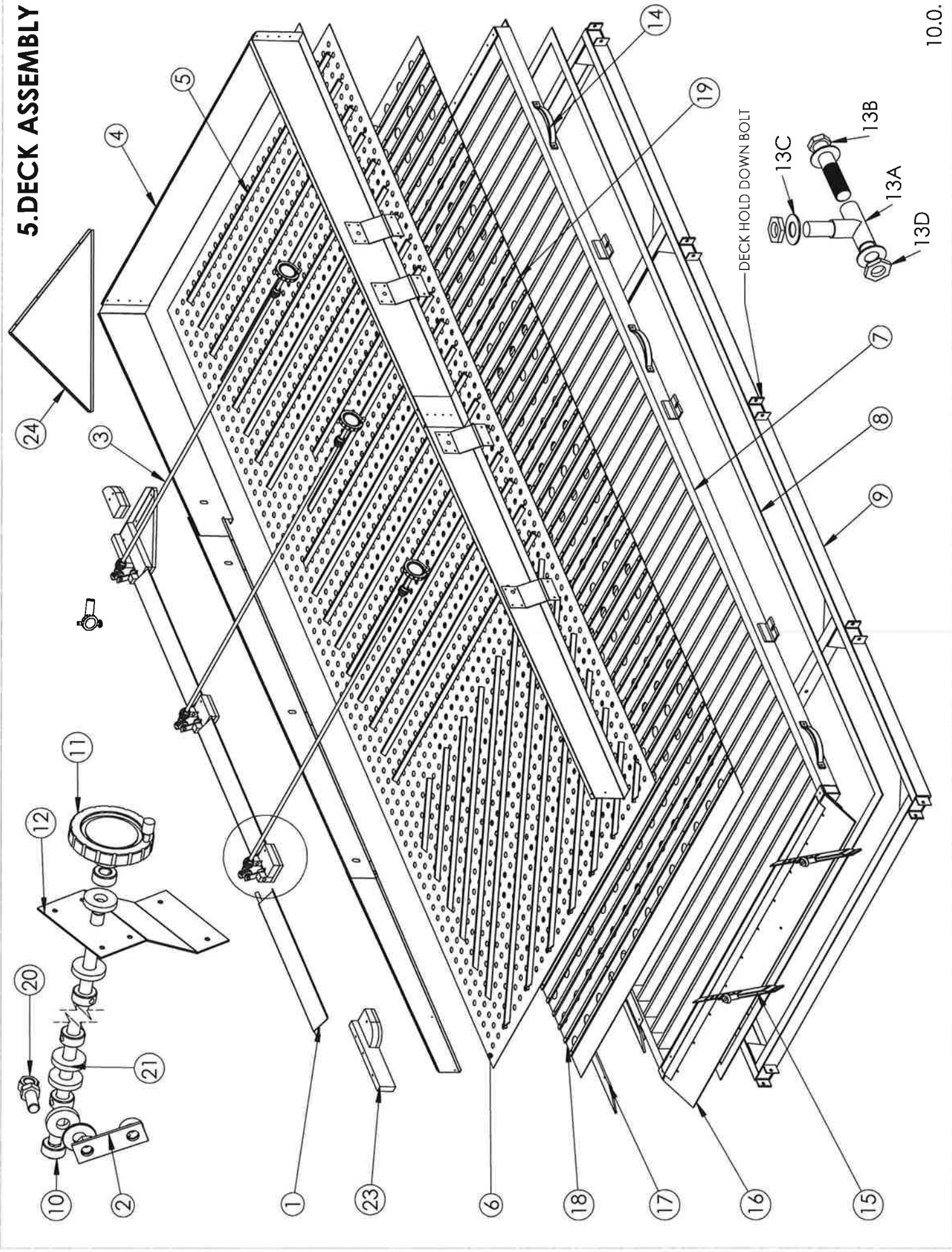

5.DECK ASSEMBLY

REF NO	DESCRIPTION	PART ID	QTY
1	DECK SIDE DISCHARGE GATE	SDK321	(1)
2	DECK CONTROL GATE LINKAGE	SDK328	(4)
3	DECK CONTROL GATE ROD	RDK332	(4)
4	DECK SIDE RAIL SET LH	RDK301	(1)
	DECK SIDE RAIL SET RH	RDK302	(1)
5	RIFFLE SET LH	RDK375	(1)
	RIFFLE SET RH	RDK376	(1)
6	DECK OVERCOVER		
	10 MESH DECK OVER COVER W/RIVETS	RDK233	(1)
	16 MESH DECK OVER COVER W/RIVETS	RDK235	(1)
	30 MESH DECK OVER COVER W/RIVETS	RDK237	(1)
7	DECK FRAME LH	RDK199	(1)
	DECK FRAME RH	RDK200	(1)
8	1/16" x 1.5" PSA NEOPRENE,PER FOOT	ZDK900	34 ft
9	DECK CARRIAGE RH	RDK500	(1)
	DECK CARRIAGE LH	RDK499	(1)
10	1/2 COLLAR	ZNT775	(20)
11	PLASTIC SPINNER KNOB	ZBF003	(4)
12	DECK CONTROL GATE ROD ANGLE LH	SDK333	(4)
	DECK CONTROL GATE ROD ANGLE RH	SDK334	(4)
13A	DECK HOLD DOWN BOLT	SDK522	(9)
13B	3/8" x 3 3/4" HEX CAP SCREW	ZBT432	(18)
13C	3/8" FLAT WASHER	ZWA930	(20)
13D	3/8" NYLON LOCK NUT	ZNT375	(16)
14	DECK HANDLE	ZDK001	(4)
15	COMPLETE CUTTING FINGER	HDK154	(3)
16	DECK END DISCHARGE APRON	RDK265	(1)
17	DECK SIDE DISCHARGE APRON	RDK960	(1)
18	UNDER COVER SET - A DECK	RDK220	(1)
	UNDER COVER SET - B DECK	RDK221	(1)
19	PARTING STRIPS SET	RDK245	(1)
20	ACME WELDED EYEBLOT	HVS504	(6)
21	1/2" RUBBER WASHER	ZDK917	(16)
22	ROCK TRAP GATE	SDK320	(1)
23	POLY DECK BLOCK SET - LH	RDK351	(1)
	POLY DECK BLOCK SET - RH	RDH350	(1)
24	4800 UNIVERSAL CUT OFF BOARD (LH & RH)	QDK400	(1)

6. COUNTER BALANCE ASSEMBLY

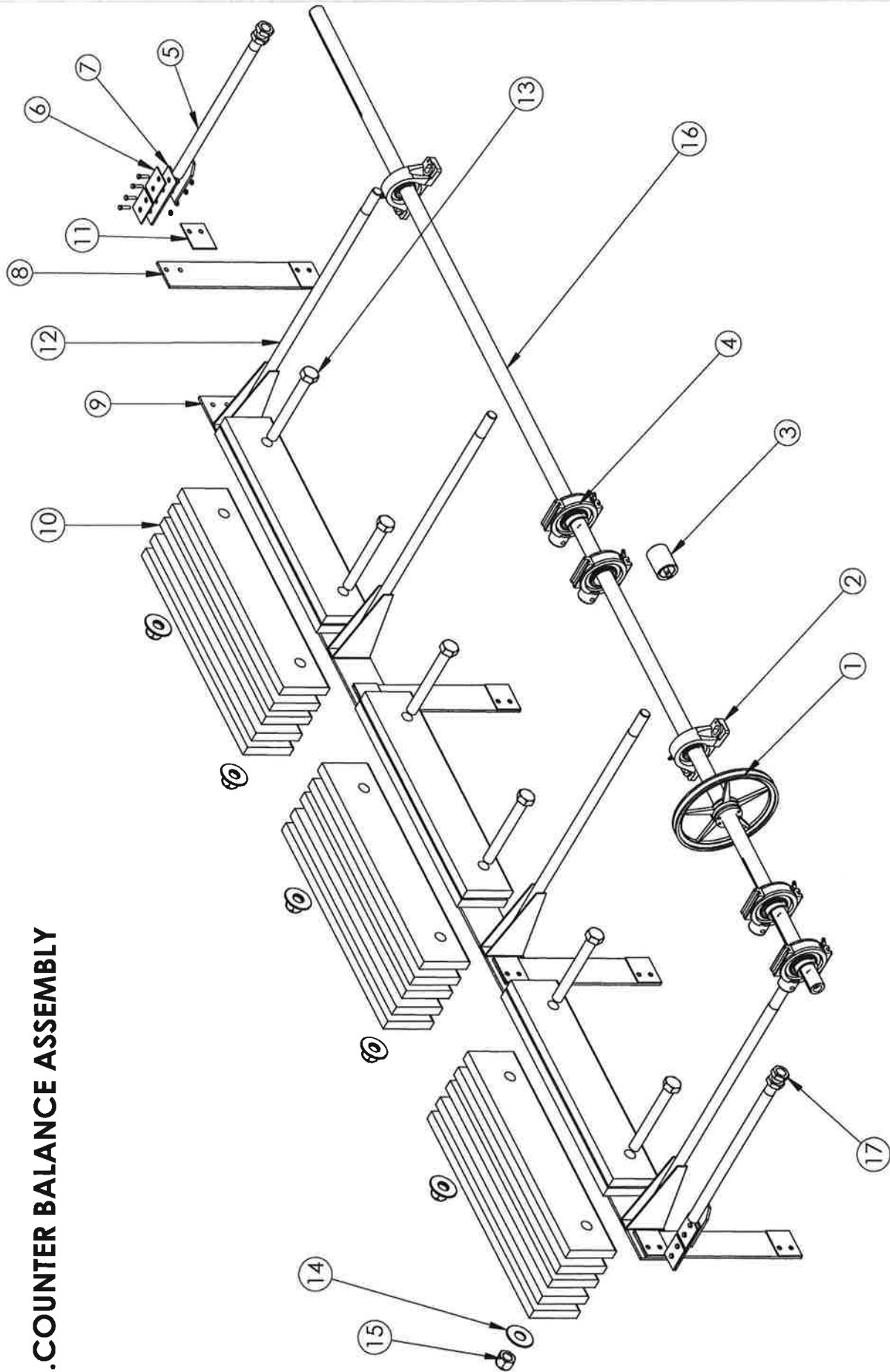

6.COUNTER BALANCE ASSEMBLY

REF NO	DESCRIPTION	PART ID	QTY
1	BK100H SHEAVE	ZBK810	(1)
2	1 7/16" PILLOW BLOCK BEARING	ZBG211	(4)
3	ECCENTRIC HEART	UEC510	(8)
4	1 15/16" TAKE UP BEARING	ZBG230	(8)
5	ECCENTRIC DRIVE ROD COMPLETE	SEC340	(4)
6	SCOTCH PLY BACK PLATE 1 ¾" X 2 ½"	SSB102	(8)
7	SCOTCH PLY TOGGLE 2" X 5 ½"	ZFG130	(4)
8	SCOTCH PLY TOGGLE 3 x 16.5	ZFG100	(4)
9	COUNTER WEIGHT MOUNT ANGLE - LH	REC299	(1)
	COUNTER WEIGHT MOUNT ANGLE - RH	REC300	(1)
10	COUNTER WEIGHT PLATE - 1 X 5 - 24	REC301	(21)
11	BACKING PLATE 2 X 2 ½"	SSB101	(8)
12	COUNTER BALANCE DRIVE ROD	REC320	(4)
13	1" x 8" HEX CAP SCREW	ZBT615	(12)
14	1" FLAT WASHER	ZWA950	(12)
15	1" NYLON LOK NUT	ZNT510	(12)
16	ECCENTRIC SHAFT	REC350	(1)
17	1" JAM NUT	ZNT900	(8)

7. AIR CHEST ASSEMBLY

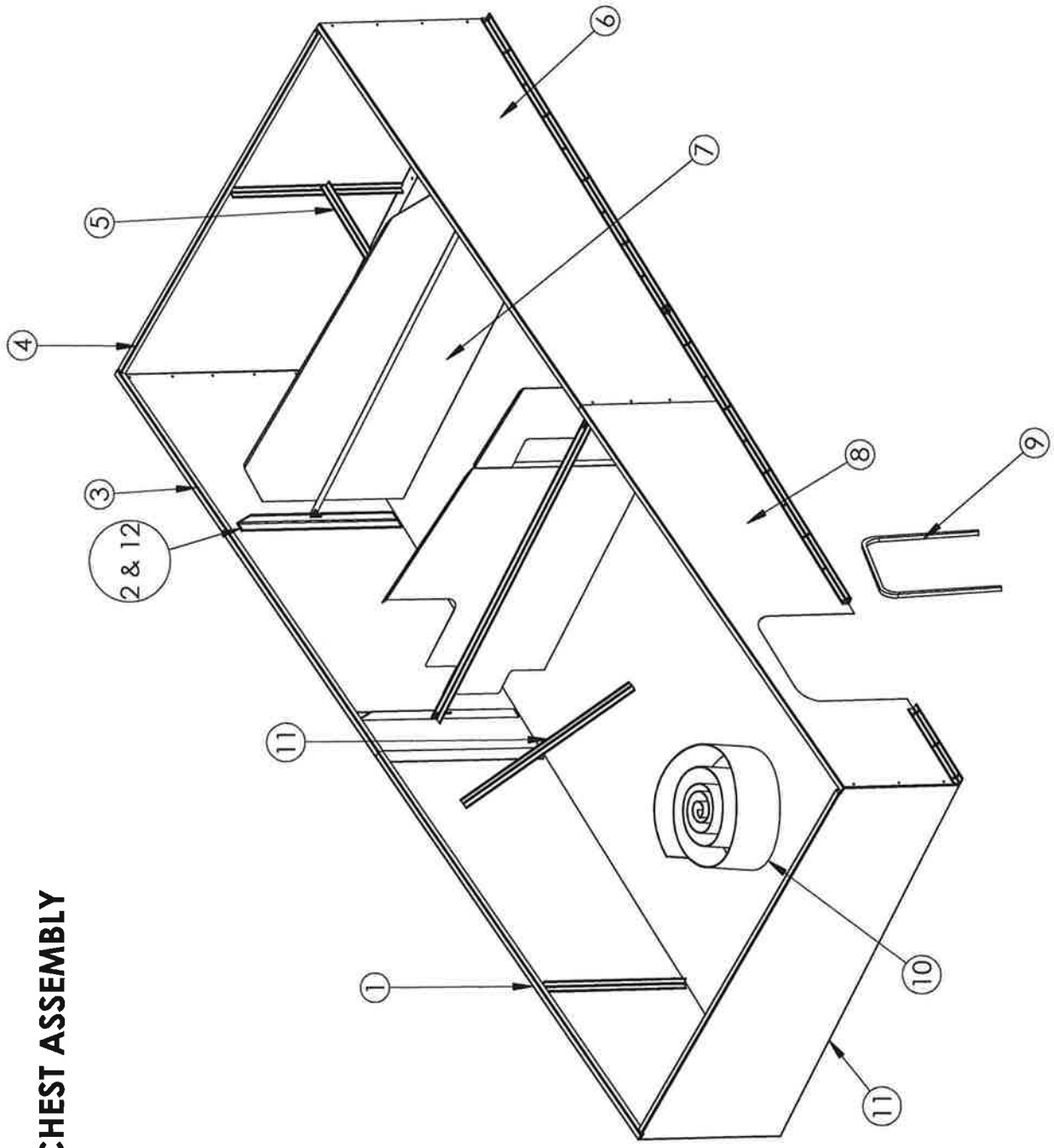

7. AIR CHEST ASSEMBLY

REF NO	DESCRIPTION	PART ID	QTY
1	AIRCHEST HIGH SIDE DIS.QTR PANEL RH	RAC130	(1)
	AIRCHEST HIGH SIDE DIS.QTR PANEL LH	RAC129	(1)
2	AIRCHEST ANGLE BRACE - HIGH SIDE	QAC170	(1)
3	AIRCHEST HIGH SIDE FEED QTR PANEL RH	RAC140	(1)
	AIRCHEST HIGH SIDE FEED QTR PANEL LH	RAC139	(1)
4	AIRCHEST FEED END PANEL RH	RAC150	(1)
	AIRCHEST FEED END PANEL LH	RAC149	(1)
5	AIRCHEST BRACE - HIGH SIDE	QAC160	(1)
6	AIRCHEST LOW SIDE FEED QTR PANEL RH	RAC110	(1)
	AIRCHEST LOW SIDE FEED QTR PANEL LH	RAC109	(1)
7	AIRCHEST DIVIDER SET,RH	RAC200	(1)
	AIRCHEST DIVIDER SET,LH	RAC199	(1)
8	AIRCHEST LOW SIDE DIS.QTR PANEL RH	RAC100	(1)
	AIRCHEST LOW SIDE DIS.QTR PANEL LH	RAC099	(1)
9	PLASTIC TRIM PER FOOT	ZHY330	1.5 FT
10	NRV BOOT	RAC300	(1)
	ADHESIVE BACKED VELCRO HOOK MATERIAL	VAC104	(1)
11	AIRCHEST DISCHARGE END PANEL RH	RAC120	(1)
	AIRCHEST DISCHARGE END PANEL LH	RAC119	(1)
12	AIRCHEST BRACE, LOW SIDE	SAC170	(1)

8. BLENDER ASSEMBLY

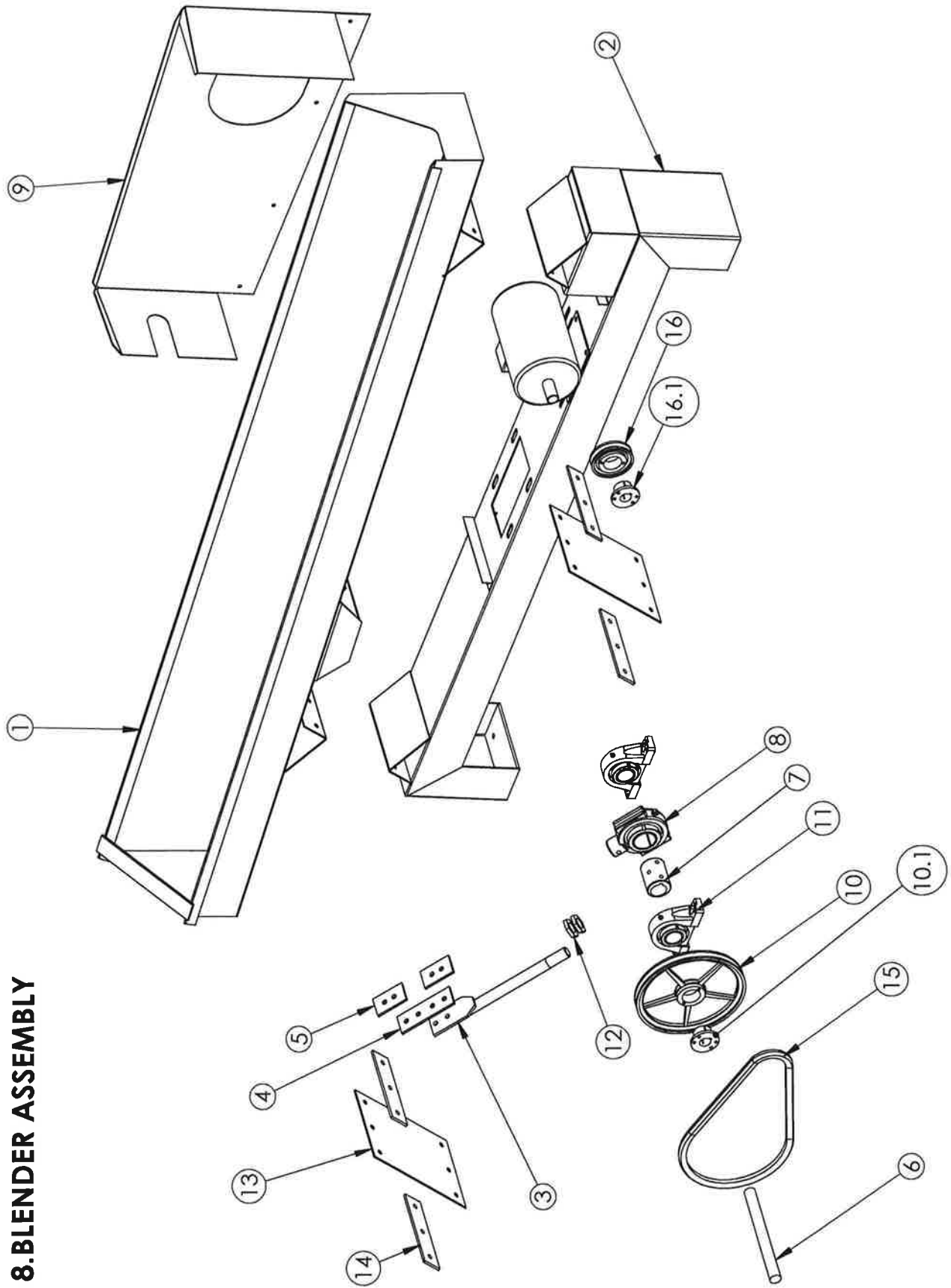

8. POWER BLENDER ASSEMBLY

REF NO	DESCRIPTION	PART ID	QTY
1	BLENDER TROUGH, RH	SBP100	(1)
	BLENDER TROUGH, LH	SBP099	(1)
2	BLENDER BASE LH OR RH	RBP200	(1)
3	M/C STONER DRIVE ROD	UEC340	(1)
4	PUSH ROD SCOTCHPLY TOGGLE	ZFG130	(1)
5	SCOTCHPLY BACKUP PLATES	SSB102	(2)
6	PB ECCENTRIC SHAFT 9" LONG	HBP040	(1)
7	ECCENTRIC HEART COMPLETE	UEC510	(1)
8	TAKE UP BEARING	ZBG230	(1)
9	BLENDER GUARD LH	QBP499	(1)
	BLENDER GUARD RH	QBP500	(1)
10	BK100 SHEAVE	ZBK810	(1)
10.1	H BUSHING 1 3/16	ZBK374	(1)
11	1-3/16" PILLOW BLOCK BEARING	ZBG118	(2)
12	JAM NUT	ZNT900	(2)
13	SCOTCHPLY TOGGLE 8 x 12	ZFG155	(2)
14	SCOTCHPLY BACKUPS	SBP601	(4)
15	B51 BELT	ZBK251	(1)
16	BK36H SHEAVE	ZBK805	(1)
16.1	H BUSHING 7/8"	ZBK370	(1)

9.1.FULL DUST HOOD

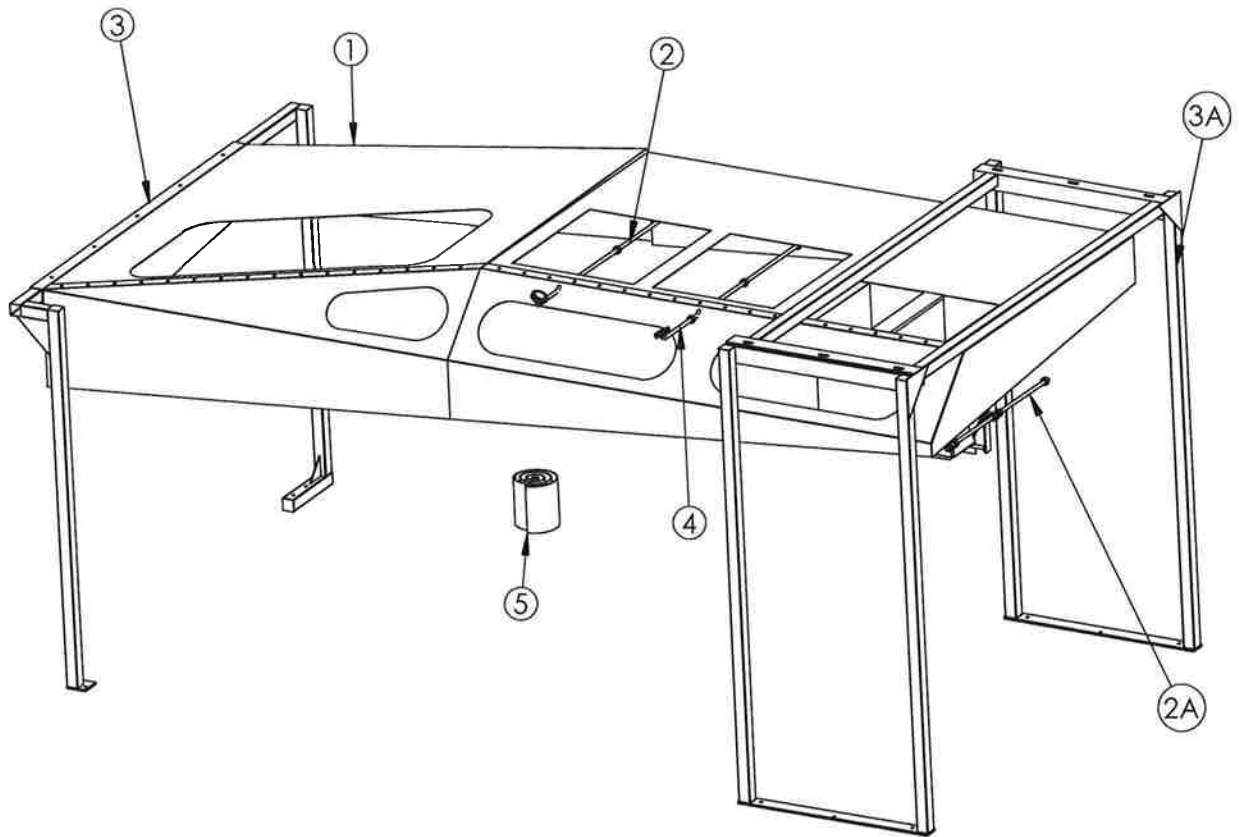

9.2.DUST HOOD FEEDER

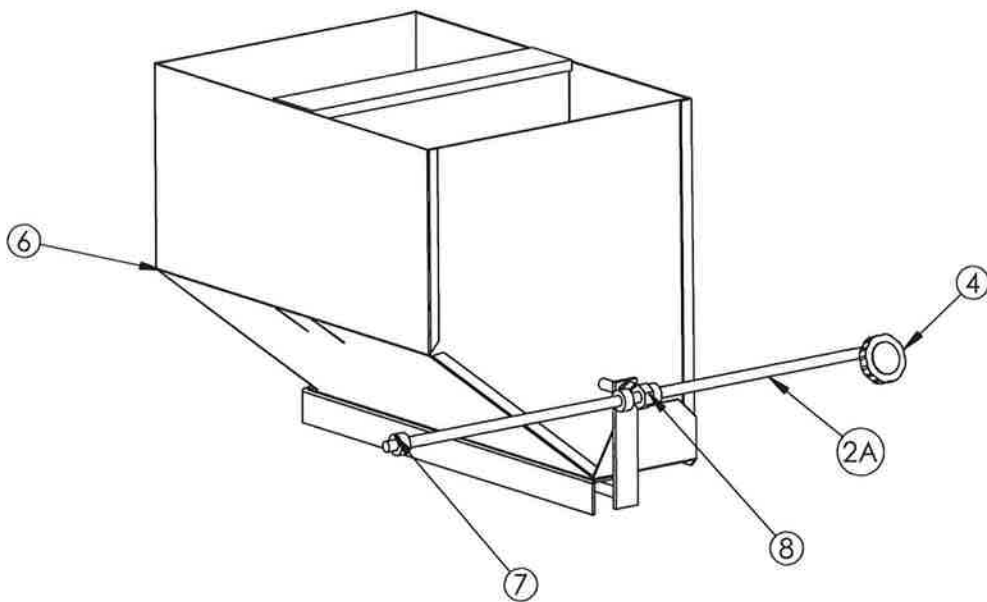

9.FULL DUST HOOD AND DUST HOOD FEEDER

REF NO	DESCRIPTION	PART ID	QTY
1	4800 LH DUST HOOD	RDH101	(1)
	4800 RH DUST HOOD	RDH102	(1)
2	4800 DUST HOOD AIR GATE ROD	RDH142	(2)
2A	4800 DH FEED CONTROL ROD	SDH022	(1)
3	4800 LH DH DISCHARGE END MT POST	RDH135	(1)
	4800 RH DH DISCHARGE END MT POST	RDH134	(2)
3A	4800 DUST HOOD MT POST	RDH136	(1)
4	4800 DH AIR GATE ROD	RDH142	(2)
5	4800 LH NRV/DUAL LOCK DH BOOT	RDH321	(1)
	4800 RH NRV/DUAL LOCK DH BOOT	RDH320	(1)
6	4800 DUST HOOD FEEDER LH	SDH117	(1)
	4800 DUST HOOD FEEDER RH	SDH120	(1)
7	1/2" COLLAR	ZNT775	(8)
8	M/C DECK SQ.HEAD EYE BOLT 1"	SDK500	(1)

10.1.DISCHARGE HOPPER

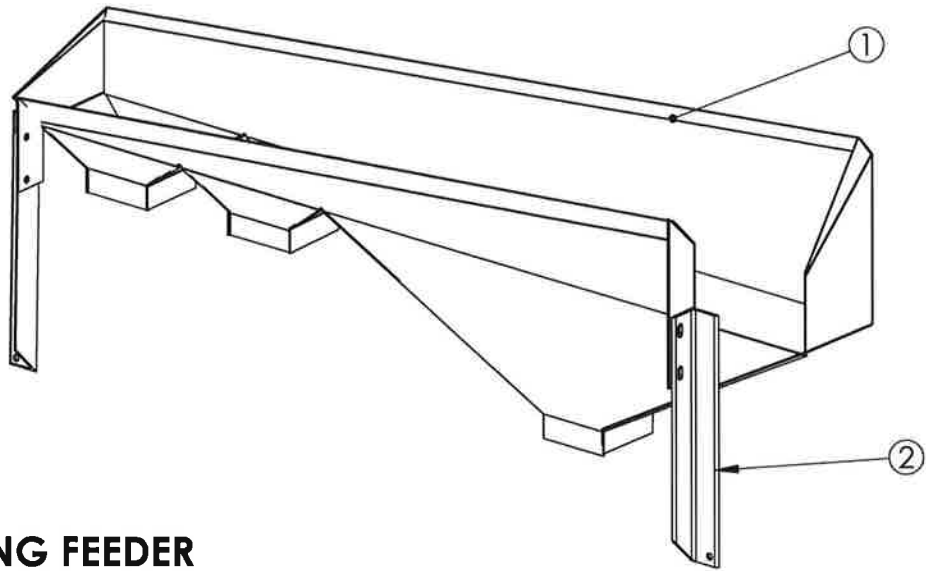

10.2.ASPIRATING FEEDER

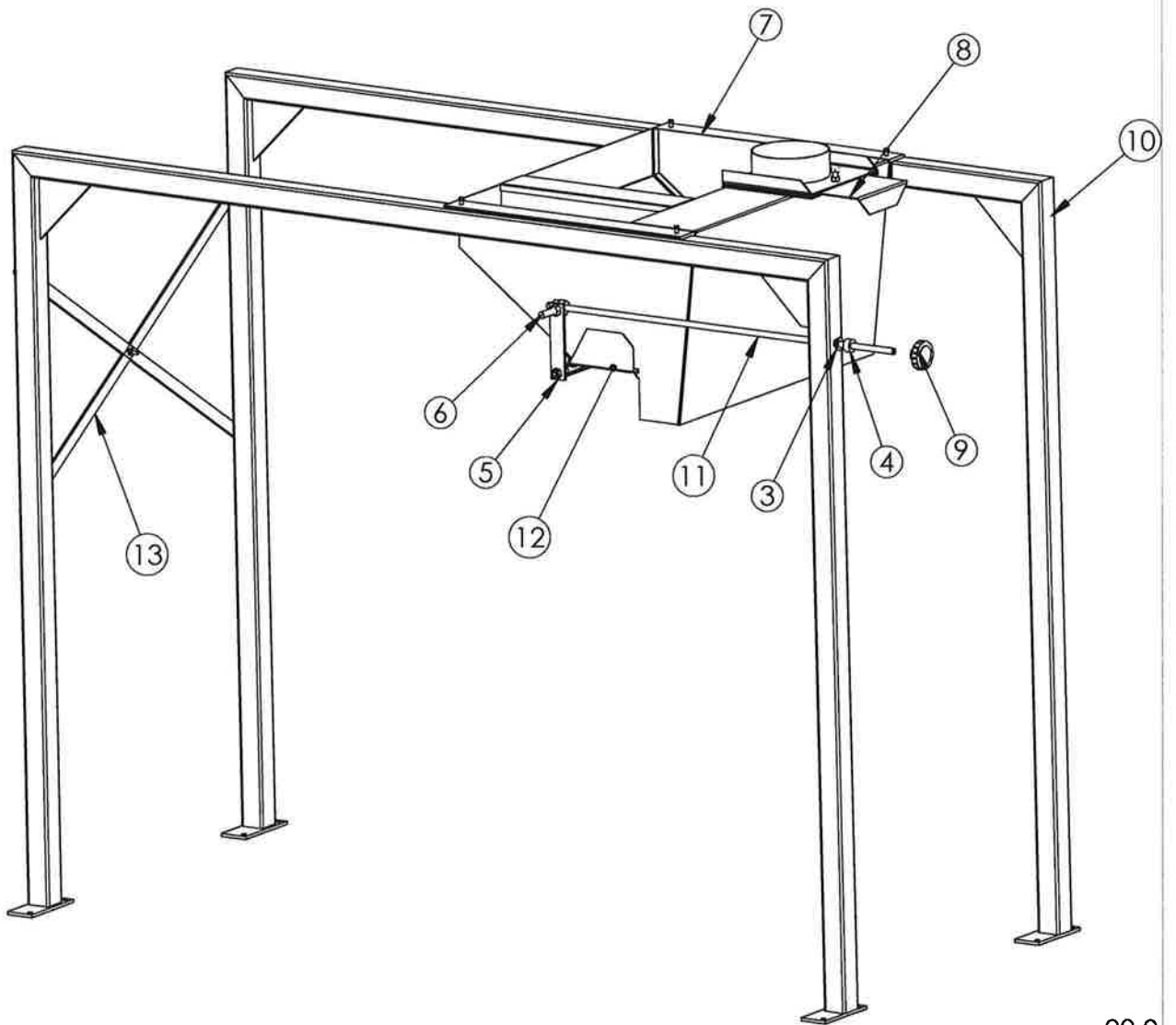

10.DISCHARGE HOPPER AND ASPIRATOR FEEDER

REF NO	DESCRIPTION	PART ID	QTY
1	4800 DISCHARGE HOPPER , LH	RCD001	(1)
	4800 DISCHARGE HOPPER , RH	RCD002	(1)
2	DISCHARGE HOPPER MOUNT SET	SCD200	(1)
3	NYLON WASHER	W2P	(1)
4	½" COLLAR	ZNT775	(6)
5	ASPIRATING FEEDER FEED CONTROL LINK W/NUTS	SFA330	(1)
6	EYEBOLT	SDK500	(2)
7	4800 ASP. FEEDER HOPPER COMPLETE LH	RFA099	(1)
	4800 ASP. FEEDER HOPPER COMPLETE RH	RFA100	(1)
8	4800 ASP. FEEDER AIR CONTROL SLIDE	SFA239	(1)
9	PLASTIC KNOB WITH RECIPROCAL HANDLE	ZBF003	(2)
10	4800 ASP. FEEDER OUNTING FRAME	SFA101	(1)
11	ASPIRATED FEEDER FEED CONTROL ROD	SFA302	(1)
12	FEED TRAY LH	SFA219	(1)
	FEED TRAY RH	SFA220	(1)
13	M/C ASP. FEEDER MOUNTING PART(X BRACE)	SFA115	(1)

11. HYDRAULIC ASSEMBLY

REF NO	DESCRIPTION	PART ID	QTY
1	ELECTRIC HYDRAULIC VALVE-12C11S-E11H-3VALVE	ZHY121	(1)
2	HYDRAULIC FILTER HEAD	ZHY150	(1)
3	HYDRAULIC FILTER REPLACEMENT CARTRIDGE	ZHY151	(1)
4	HYDRAULIC MOTOR ONLY	ZHY102	(1)
5	HYDRAULIC PUMP ONLY	ZHY101	(1)
7	HYDRAULIC POSITION CYLINDER - 2 X 6	ZHY141	(1)
8	HYDRAULIC CYLINDER 2 X 4	ZHY130	(1)
8.1	HYDRAULIC POSITION CYLINDER 2 X 4	ZHY131	(1)
9	HYDRAULIC CHECK VALVE	ZHY120	(1)
10	HYDRAULIC FITTING 1/4" TEE	ZHY285	(2)
	HYDRAULIC FITTING 1/4" CLOSE NIPPLE	ZHY286	(2)
11	3/8" X 90 STREET ELBOW	ZHY281	(2)
12	ADAPTER 9205 - 4 X 4	ZHY260	(16)
	ADAPTER 9315 - 6 X 4	ZHY230	(24)
	ADAPTER 9205 - 4 X 6	ZHY240	(24)
	ADAPTER 9205 - 6 X 6	ZHY250	(2)
13	HYDRAULIC FITTING 04U-104	ZHY200	(40)
	HYDRAULIC FITTING 06U-106	ZHY210	(2)
	HYDRAULIC FITTING 06U-104	ZHY215	(2)
	HYDRAULIC FITTING 06U-R66	ZHY220	(2)
14	MAXI-CAP FLOW RESTRICTER	ZHY271	(2)

