

Operations manual

Oliver™

Innovate. Build. Repeat.



Maxi-Cap Series

Destoner

Version 1.0 | 1/5/23

Table of Contents

Contents	Page
I. Introduction	2
II. Installation	3-4
Uncrating	
Deck Requirements	
Foundation Requirements	
Electrical Requirements	
Clean Air Source	
III. How does a Stoner Work?	5-7
The Process of Stratification	
The Theory in Practice	
IV. Controls of your Maxi-Cap	8-10
The Deck	
The Four Adjustments	
Feed Rate	
Tilt	
Eccentric Speed	
Air Control	
V. Start-up and Operation	11-14
Initial Start-up	
Starting Procedures	
Set Up	
Starting your Oliver	
Adjusting Air Pattern	
Adjusting Side Tilt	
Adjusting Eccentric Speed	
Increasing Capacity	
VI. Maintenance	15-17
Decks	
Drives	
Vari-Speed	
Hydraulics	
Oil and Filters	
Purging Air	
Bearings	
Ordering Repair Parts	

I. INTRODUCTION

Congratulations! You have just purchased a well-built, machine that can earn substantial profits for you, if you take time **right now** to understand the Oliver Stoner and how it works. The Operating instructions Manual contains new, valuable information that operators will want to read. Please take a few minutes to read the instructions to help eliminate many of the problems frequently encountered.

Keep in mind at all times that the stoner is not a "cure all" for the processor's problem. The de stoner is a specialized piece of machinery designed to do one job very well.

THE STONER SEPARATES PARTICLES OF A SIMILAR SIZE THAT DIFFER IN WEIGHT, CONCENTRATING THE HEAVY MATERIAL. THE STONER SHOULD NOT BE USED AS A CLEANING MACHINE TO REMOVE DUST, DIRT STICKS AND OTHER FOREIGN MATERIAL FOUND IN UNPROCESSED MATERIAL. In all

processing situations, the best results are obtained from the stoner when the product has been thoroughly pre-cleaned and sized, using the proper equipment for these purposes. Under these conditions, the stoner is then able to show what it can really do!

II. INSTALLING YOUR OLIVER STONER

All Oliver Maxi-Cap Stoners are operated on test blocks at the factory for a minimum of 50 hours. During and after operation, the drive train and controls are checked to insure that they will operate satisfactorily when you set them up and punch the switch-.

UNLOADING YOUR OLIVER

Although your Oliver is built to give years of service, it can be damaged while being unloaded. While unloading the stoner, do not put anything on the separating deck. If the deck is damaged, good separations are impossible. Also, be careful not to puncture the filter screens located on the sides of the machine. If the filter screens are damaged, dirt may be sucked into the machine and may plug the deck.

Immediately after unloading your Oliver Stoner, inspect for carrier damage. If the machine is impaired in any way, it was caused in transit and a claim should be filed with the carrier.

FOUNDATION REQUIREMENTS

A solid foundation is required for your Oliver Stoner. False vibrations from flooring can ruin the separations quality of the machine. A six inch concrete slab makes an ideal platform but is not-essential. "Many customers operate Oliver Stoners on wooden floors with no problems. If you feel that your floor is insecure, please contact the factory for recommendations.

When locating your stoner, be sure that you leave adequate clearance to operate the controls and to remove the deck for changing or cleaning. To operate the controls and provide normal maintenance, we recommend a minimum of 30 inches clearance. A space approximately equal to the dimensions of the deck is adequate for deck removal from either end.

ELECTRICAL CONNECTION

After your stoner is mounted on a secure foundation, you are ready to install the motor and make the connections. If you ordered your stoner with a motor, it will be installed at the factory; and you will only be required to make the necessary electrical connections. Factory-installed motors will be wired for 60 cycle, 220 volt, 3-phase power unless otherwise specified. If your power supply is different and you order a motor, please inform the factory well in advance of the shipping date, so the motor can be correctly installed.

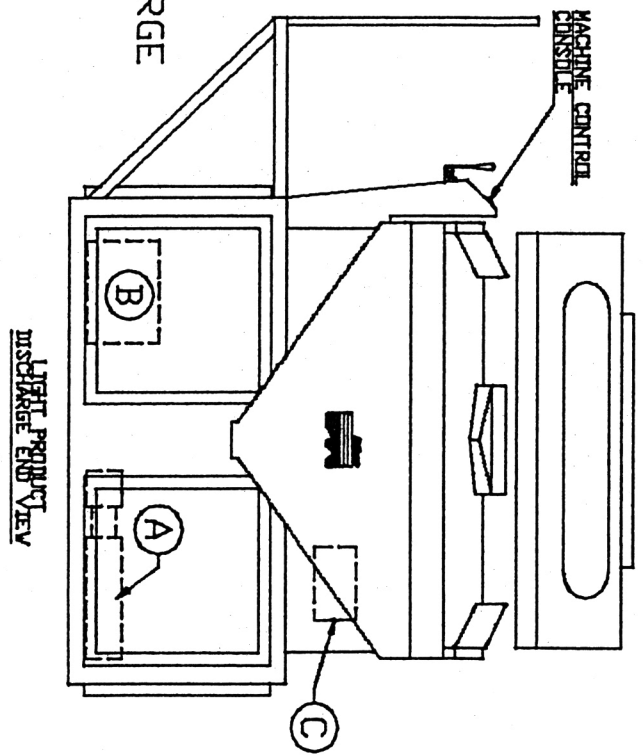
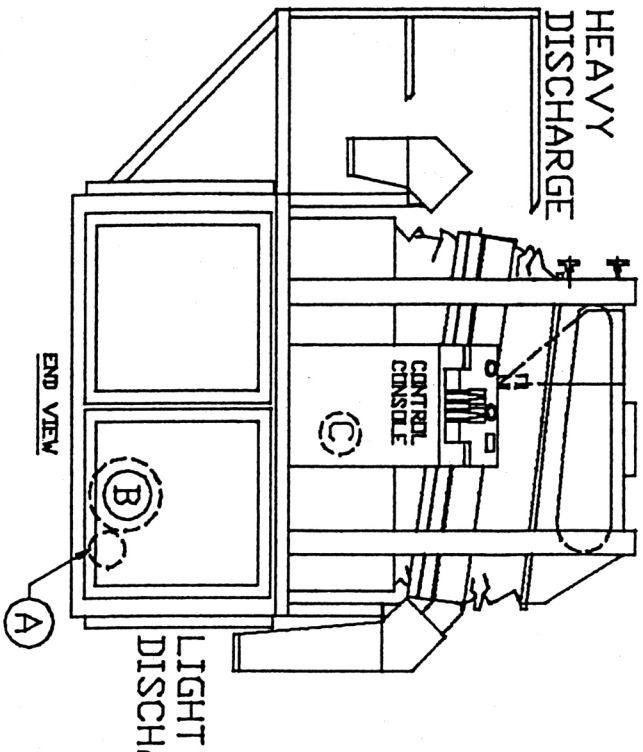
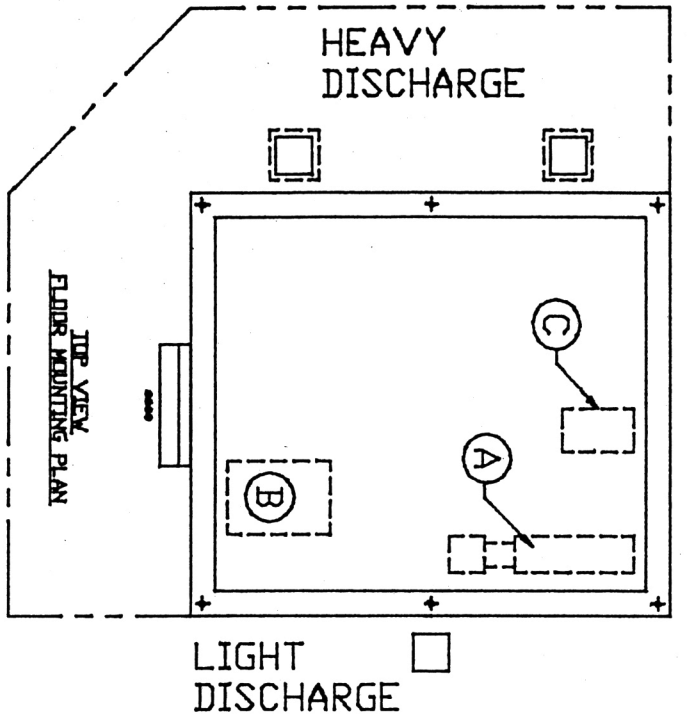

PROVIDE FLEXIBLE ELECTRICAL CONNECTIONS FOR THE FOLLOWING MOTORS

- A 1/2HP SYSTEMS MOTOR
- B BLOWER DRIVE MOTOR
- C DECK DRIVE MOTOR

If you supply your own motor, be sure that it is large enough to carry the load as specified in our literature.

The machine interior is accessible by removing the filter panels. Be sure that the motor pulley is directly in line with the fan shaft pulley and that the motor shaft and the fan shaft are parallel. After the motor is mounted, adjust the belts to the proper tension. When belts are too tight, excessive strain is placed on the bearings and will shorten bearing and belt life. When belts are too loose, they will slip. This will cause the belts and pulleys to overheat and shorten their life.

To check for proper belt tension, first turn the machine off. Then apply pressure to the side of the belt midway between the pulleys. The belts should deflect approximately 1/2 inch. After the machine has operated for 8 to 10 hours, check the belts again. It is normal for new belts to stretch slightly, so the belt tension may have to be adjusted.

When your electrician wires the motor, be sure that he connects it so that it will run in the proper direction. All shafts, motor shaft, fan shaft and eccentric shaft, should run counterclockwise when viewed from the side of the machine where the motor is installed. Proper fan rotation is very important and at least half of the problems with new stoners can be traced back to incorrect rotation.

CLEAN AIR SOURCE

Some customers need to bring in clean outside air rather than to draw dusty plant air through the filters installed on the machine. Connect your ductwork to one of the filter openings on your machine. We recommend that you keep the ductwork shorter than 20 feet or use a booster fan. The clean air source should have a filter area not less than the area of the deck surface. Please call the factory for questions on clean air returns.

After the stoner is installed and the motor wired so the fans rotate in the proper direction, familiarize yourself with the theory behind stoner operation and the proper usage of the controls before attempting to make a separation.

III. HOW DOES A STONER WORK?

All gravity separators and stoners utilize the same principles to create a separation. Once these principles are understood, it is usually a simple step to adjust a stoner to produce an optimum separation.

About 250 B.C., Archimedes discovered the law of specific gravity, which is "ALL BODIES FLOATING IN OR SUBMERGED IN A LIQUID ARE BUOYED UP BY A FORCE EXACTLY EQUAL TO THE WEIGHT OF THE LIQUID THEY DISPLACE." The specific gravity of a particle is the ratio of its density to some standard substance, the standard usually being water with a unit of 1. Particles having a specific gravity of less than 1 will float and particles with a specific gravity greater than 1 will sink.

Oliver Stoners use air as a standard rather than water. Since air is lighter than water, the relative difference between particles of differing weights is widened. For this reason, the stoner is a very sensitive machine and, when operated correctly, can produce a very precise separation.

TBE PROCESS OF STRATIFICATION

Air is used as the weighing medium for the process of stratification. Stratification occurs by forcing air through the particle mixture so that the particles rise or fall according to their relative weight to the air. Figure 1 below represents a cross section of the stoner directly over a fan. A particle mixture has been introduced on top of the screen deck with the fans off.

In Figure 2, the fan has been turned on, so that the heaviest particles rest on the surface of the deck and the lightest particles are completely free of the surface of the deck. Proper regulation of the airflow at this time is critical or all particles will be blended and lifted free from the separating surface by excess air (Figure 3).

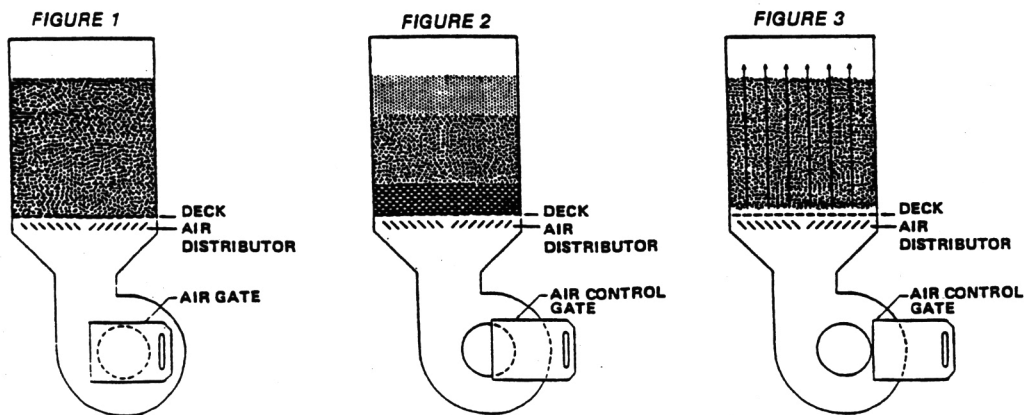

THE THEORY IN PRACTICE

Figure 4 represents a top view of the ideal situation in the operation of a stoner.

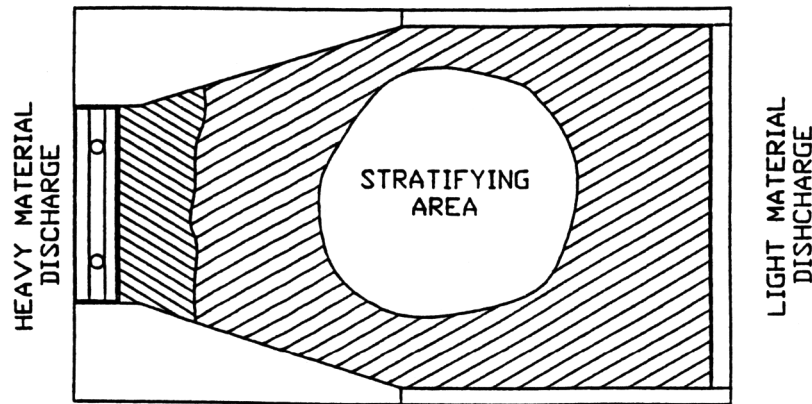

FIGURE 4

The product mixture, similar to Figure 1, falls from the feeder onto the deck. The area immediately under the feeder is called the stratification zone. In this area, the vibration of the deck and the lifting action of the air combine to stratify the material into layers with heavier layers on the bottom and lighter layers on the top as shown by Figure 2. Separation cannot occur until the material becomes stratified. The size of the stratification area will depend on the difficulty of the separation and on the capacity at which you are processing. At no time should it exceed 1/3 of the deck surface.

The more difficult the separation, the greater is the area that is required to obtain proper stratification. For example, the stratification area is large when separating mud clods from saleable beans, because there is relatively little difference in weight. However, the stratification area is small when removing rocks or stones from beans, because there is a large difference in weight. Higher capacities likewise require greater areas for stratification.

Once the material is stratified, the vibrating deck begins pushing the heavier layers in contact with the deck uphill toward the heavy discharge. At the same time, the upper lighter layers, which do not contact the deck, begin to float downhill toward the clean product discharge.

It should be noted that, since the stratification process is not instantaneous, some of the heavier materials will be carried down the deck toward the discharge end before they can sink to the bottom of the fluidized bed. This is normal and acceptable as long as the heavy trash does not flow off the deck with the cleaned product. When you are not making a proper separation, it is an indication of one of the following problems.

1. Feed rate too high - stratification area too large.
2. Machine improperly adjusted - improper stratification.
3. Material not suitable for separation on a stoner.

Each of the above is a distinct problem and will be discussed fully in this manual.

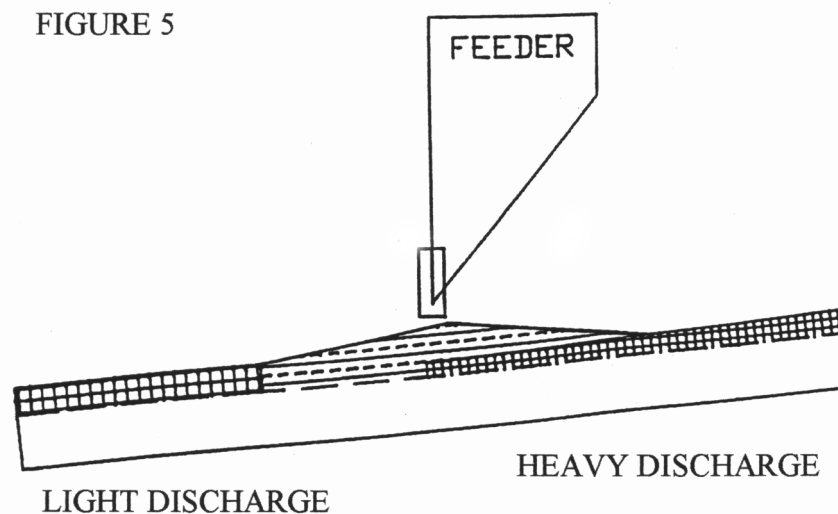

This illustration is a sectional diagram of what occurs on a stoner deck. Compressed air forced through the mesh of the deck cover lift the lighter particles upward, while heavier particles sink against the air currents and come to rest on the deck surface, providing the air is properly adjusted. The heavier particles are forced to travel uphill by mechanical action, while the lighter particles float downhill on a film of air.

While stoners have greater capacities than gravity separators, based on square feet of relative deck area, there is a limit as to the amount of feed flowing to the deck. As the feed is increased, the stratifying area is also increased. The stratifying area should not occupy more than 1/3 of the entire deck area.

IV. CONTROLS OF THE OLIVER STONER

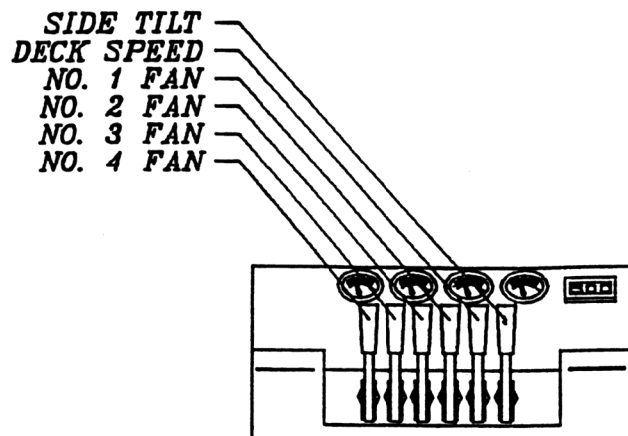

(MODEL 1205 ILLUSTRATED)

Before starting to operate the machine, it is necessary to have a thorough understanding of the controls and their location on the Oliver Stoner. PROPER REGULATION OF CONTROLS IS THE KEY TO SUCCESSFUL STONER SEPARATION. PROPER USE OF THESE CONTROLS SHOULD BE UNDERSTOOD PRIOR TO ATTEMPTING AN ACTUAL SEPARATION.

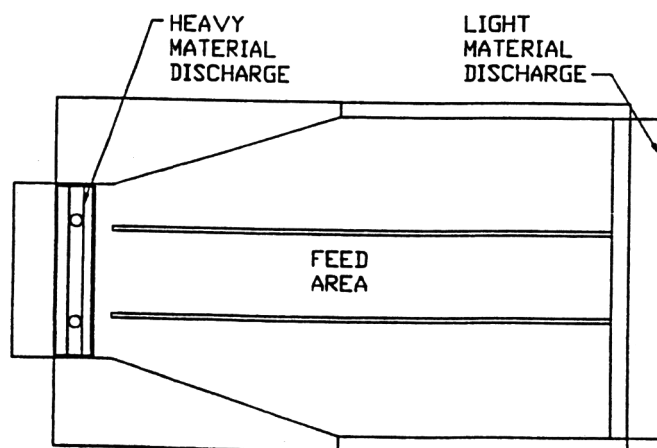

FIGURE 7

THE DECK

The most important part of the stoner is the deck, because it is the main separating surface. It consists of a carefully constructed aluminum frame to counteract false vibrations with a screen or cloth overcover that is the surface on which the separation takes place.

The highest or uphill end of the deck is the heavy discharge and the lower or downhill portion of the deck is the light material discharge.

Oliver Maxi Stoners have up to four heavy discharge traps depending on the model. The Oliver Model 305 Stoner has one stone trap. The Model 605 Stoner has two, the Model 905 Stoner has three traps, and the Model 1205 Stoner has four stone traps.

This feature of the deck will be discussed further in these instructions, but knowledge of their location is important as well as understanding the controls that affect the four variable adjustments in the Oliver Stoner.

THE FOUR ADJUSTMENTS

All Stoners have four variable adjustments that must be properly adjusted and balanced to obtain optimum separations. These are Feed Rate, Tilt, Eccentric Speed and Air Control. We will discuss the controls for each of these variables in turn. (Please refer to Figure 6.)

FEED RATE

The feed rate control is located on the feeder and controls the amount fed onto the separating deck. Whether you use standard Oliver feeders or supply your own feeder, you must have a means of controlling the feed. The feed rate, whether fast or slow, should be uniform and free of surges. Surges in the incoming feed will show up in the discharge of the machine as a poor quality separation. We suggest the use of surge bins above the feeder, if processing will be interrupted.

Generally, the average feed rate is determined by the average capacity of the processing line of equipment. For optimum separation on your stoner, your feed rate should be as low as possible without falling below the minimum feed rate at which the deck can be fed and still obtain the necessary separation. When starting your stoner, always start at the minimum feed rate; obtain your required separations, then increase the feed rate to the desired capacity.

TILT

Tilt is the difference in the elevation between the high end of the deck and the low end of the deck. Increasing tilt will cause the material to shift toward the low end of the deck. Decreasing tilt will cause the material to shift toward the high side of the deck. Normally, the best separations are obtained when the tilt is set at or near the maximum steepness. However, care should be taken not to set the tilt too steep. The tilt is too steep when the material cannot be made to flow toward the high end of the deck by increasing the eccentric speed. Too little tilt is shown when all the material moves toward the Heavy side of the deck despite a slow eccentric speed. The tilt is adjusted by moving the tilt control lever. Pushing the lever increases side tilt and pulling the lever decreases side tilt.

ECCENTRIC SPEED

Eccentric speed and tilt are closely related. Increasing eccentric speed will cause material to be shifted towards the high side of the deck. Decreasing eccentric speed will cause the material to be shifted toward the low side of the deck. Generally, by increasing eccentric speed (which shifts material toward the high side) and increasing tilt (which shifts light material back toward the low side) a more precise separation can be obtained. Too much eccentric speed can be observed when all material shifts toward the high end of the deck despite maximum tilt being used. Eccentric speed is adjusted by moving the "More Speed" lever (4) located on the control console. Pushing the lever increases the speed and pulling the lever decreases the speed.

AIR ADJUSTMENT

Air regulation is one of the most important adjustments to be made on a stoner. The most common mistake in air regulation is the use of too much air. Separation is not made by "blowing" the light material from the heavy, but by using the controlled air flow to create the stratified layers, which are then separated by the vibrating action of the deck. Too much air will cause a boiling or bubbling action lifting the heavier particles from the deck and mixing them with the lighter top layers. Too little air will cause the material to appear sluggish and pile up on the high end of the deck.

With proper air regulation, the bed of material will be almost fluid in appearance. With the exception of the stratifying zone under the feeder, the material on the surface should be agitated and free flowing. Bubbling should be kept to a minimum, allowing the vibrating deck to make the separation.

All the controls on the stoner serve a purpose and must be balanced with the other controls to obtain optimum separation. With this understanding, we are now able to advance to making an actual separation.

V. START UP AND OPERATION

INITIAL STARTING PROCEDURES

An experienced Oliver operator should have little troubles starting the stoner and obtaining good results. However, for many of us, the confusion that results when the machine is initially turned on defies description. Many of the initial adjustments must be made soon after material is fed onto the deck. Therefore, it is a good idea to operate the machine empty for a few minutes prior to attempting to make a separation. During this period, one should listen to the machine to become familiar with the way it sounds during separation. Also, observe the oscillating action of the deck. Change the speed control to make the deck oscillate faster and slower.

Locate the tilt control lever. Operate the tilt control to increase and decrease the tilt of the deck. Remember that tilt and eccentric speed must be balanced against each other to create a smooth uniform bed of material across the deck.

Check the feeding mechanism to insure that you can control the feed rate.

Finally, open and close the air gates. Although this does not produce a visible effect on any empty deck, changes in air volume may be noted by holding your hand over the deck as the air gate controls are operated. The air control settings are the most important part of successful stoner operation.

Before turning the machine off, make one final check to insure that the fan shaft is turning in the right direction. When viewed from the main drive belt side (the belt from the motor to the fan shaft) all shafts should rotate counterclockwise.

STONER STARTING PROCEDURES

1. Close heavy discharge gates.
2. Set the eccentric speed and tilt to approximately 3/4 of their maximum setting. Close the air gates completely for small material and open partially for material larger than 1/8". Open the feed gate slightly and adjust the eccentric speed so that the material spreads uphill slightly faster than downhill.

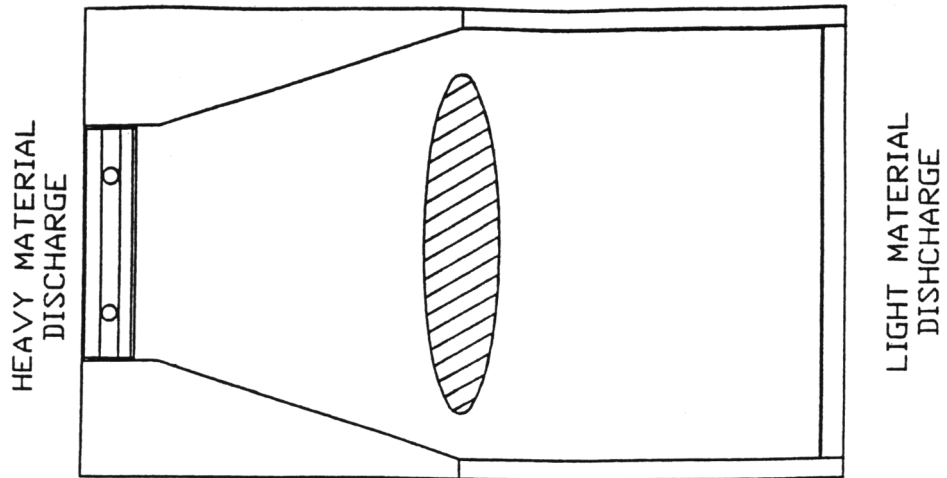

FIGURE 8

3. When 1/3 of the deck is covered, begin opening the air gate controls. As the deck continues to fill, open the air gates only enough to maintain a minimum fluidization.

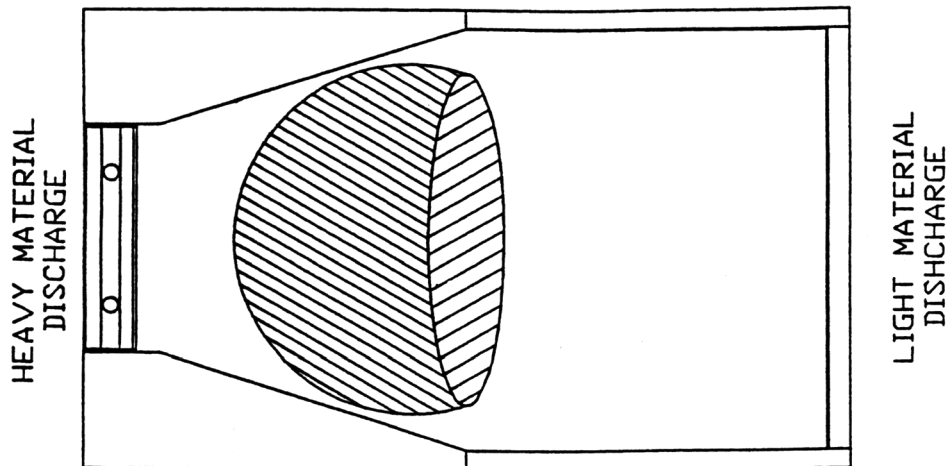

FIGURE 9

4. On many products, a zone of light material will form at the lower edge of the bed as the deck fills. This is normal and indicated that sufficient air is present. If the percentage of heavy material is high, you may note the beginnings of a heavy separation in the heavy discharge area.

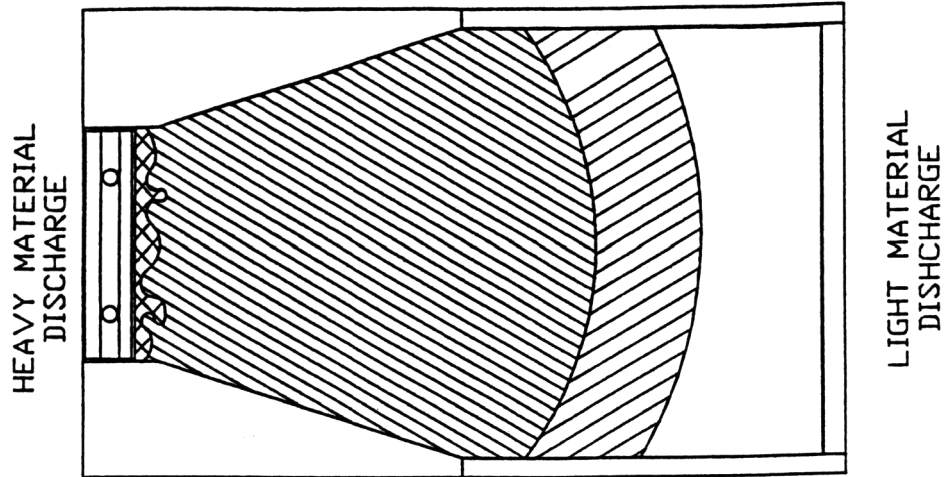

FIGURE 10

5. When the deck fills completely, the zone of lighter material at the lower edge of the bed will disappear. While maintaining a continuous feed and keeping the heavy discharge gates closed, adjust the eccentric speed, tilt and air so that the bed is slightly deeper on the heavy end as it is on the light end. Always use the minimum amount of air that will give proper stratification. As the heavy discharge area fills with heavy material, adjust the gates to maintain a bed of heavy material that extends from 6-10 inches from the heavy end of the deck.

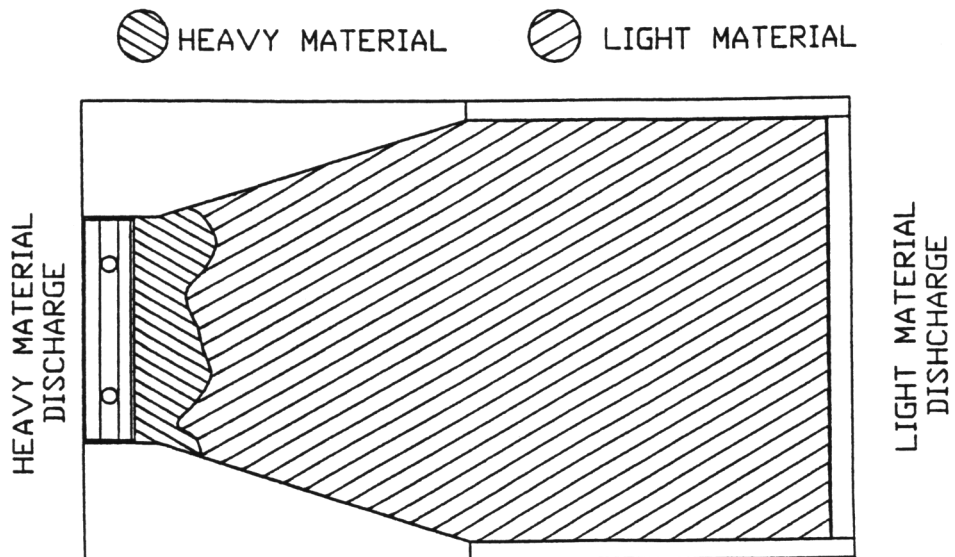

FIGURE 11

INCREASING CAPACITY

The above discussion gives the general procedure for starting and operating an Oliver Maxi Stoner. After obtaining satisfactory results at low capacity, increasing capacity is relatively simple. Only after satisfactory results are achieved, should this be tried.

1. Increasing tilt and eccentric speed.

Begin by increasing the tilt. This will cause the material to shift toward the clean product discharge. To correct this, increase the eccentric speed until the material is shifted back to the proper pattern. Continue increasing tilt and eccentric speed alternately until you have the tilt at the maximum amount where you can still maintain the correct bed depth by adjusting the eccentric control.

2. Increasing the feed rate.

Next, open the feed gate slightly. This increases the feed rate and the bed depth will increase. Wait a couple of minutes to observe the change in the material on deck. As the bed depth increases over the deck, it may be necessary to increase the air setting slightly to compensate for the thicker bed. Continue increasing the feed rate until you reach the maximum feed rate when you still obtain the desired separation.

VII. MAINTENANCE

Your Oliver Stoner is designed to give years of trouble-free service. However, as with all machinery, periodic maintenance is required to keep it in top condition. Included below is a list of some areas that can be problems, if not periodically checked.

DECKS

The deck of your Oliver is that portion of the machine that actually contacts the material and makes a separation. To maintain optimum separation, the deck should be checked frequently and cleaned or repaired as needed. Even in very clean atmospheres, dust and dirt will build up on the underside of the deck. This causes a restriction of airflow through the deck and will eventually plug the deck completely. When the deck becomes plugged, it is necessary to remove the deck from the machine and clean it. The best method of cleaning the deck is to use compressed air blowing from the top down. Thoroughly clean the entire deck. A deck that is only partially cleaned will only become plugged sooner. To check if the deck is clean, place all light on a drop cord under it. If the deck is cleaned, you should be able to see light through every opening of the deck cover. Dirty areas will show up as dark spots and should be cleaned more thoroughly.

Because decks are in direct contact with the material being separated, they are subject to abrasive wear. Inspect your decks frequently for wear. As a deck wears out, the surface becomes smoother and it becomes more and more difficult to move the heavier product out from under the lighter layers. Normally, when the wires of the deck overcover are worn halfway through, it is time to repair the deck. If the deck cover is worn completely through, there is danger of ruining the undercover which develops the air pattern. All Oliver decks with wire overcovers are built with a perforated metal undercover which develops the air pattern and a woven wire overcover, which actually makes the separation. As long as the undercover is not damaged, it is not necessary to replace it.

When rebuilding a deck, always inspect the deck thoroughly. If the ribs are all right, inspect the undercover. As long as it is not damaged, there is no need to replace it. When removing the overcover, be careful not to damage the undercover. When installing the overcover or undercover, it is best to place the deck on two sawhorses with a light underneath. By looking through the screen towards the light, you will easily be able to locate the ribs for riveting purposes. Always stretch the screen tightly. Tight screens give better separation results than loose ones. Finally, inspect the deck trim, aprons, rails and riffles; and replace what is needed.

DRIVES

There are two sets of belts and sheaves in your Oliver Stoner. These are the main drive belts or fan belts and the eccentric belt from the vari-speed to the eccentric shaft. New machines should be checked very frequently for the first few weeks, because new belts tend to stretch as they are broken in. To check belt tension, turn off the machine. Then apply pressure to the outside of the belt midway between the two sheaves. The belt should deflect approximately 1/2 inch.

VART-SPEED ASSEMBLY

The vari-speed unit changes the ratio between the driver and driven pulleys so you can change the eccentric speed. It is normal for vari-speed units to wear and it should be expected. Most customers get two or three seasons of hard use before it is necessary to replace the vari-speed, depending on the usage. The life of the vari-speed can be extended, if it is operated through its entire range at least once daily. To do this, simply cut off the feed while the machine is running. Pull the speed control lever so the eccentric slows down all the way. Then push the lever so the machine speeds up all the way. Open the feeder and reset the eccentric speed to the proper level.

BEARINGS

Your Oliver has several bearings to support the shaft. These bearings are all standard sizes and can be purchased at any bearing supply house, or we can supply new bearings. Normally, a bad bearing will first be detected by hearing an unusual rumbling noise in the machine. If you feel you have a bad bearing, it may be checked by the following method. Allow the machine to operate at least 30 minutes. Then **TURN OFF THE MACHINE**. Touch the bearing surface. If the bearing is excessively-hot, it is probably bad and must be replaced.

Most Oliver Stoners operate for many years without bearing problems. To prolong bearing life, we suggest that each bearing be given 1 to 2 shots of grease at the start of each season. Sealed bearings are installed at the factory and they give much better service, if they are not overgreased. The setscrews in all bearing should be checked and tightened periodically. Temperature changes cause the bearings and shaft to expand and shrink, these setscrews will sometimes work loose allowing the bearing races to slip along the shaft. Periodically check the bearing mounting bolts to insure that they are tight. If the bolts-become loose, the result will be false vibration. This may cause poor separation; bearing failure or a number of related problems.

ORDERING REPAIR PARTS

We maintain a complete card file on all machines that have been built by Oliver Manufacturing Company. All machines are serial numbered. To insure that you receive the correct parts, we must have the serial number of your machine. The serial number is located on the plate on the side of the operator control console.

When we receive orders for parts, we ship as soon as possible after receiving the order. Normally, we will ship by the fastest, cheapest method unless otherwise specified. Incomplete or incorrect information when ordering will cause unavoidable delay in shipping. If you have a special problem or cannot locate some of the required information, please contact us. We will work with you to provide what you need as quickly and as inexpensively as possible.

Oliver Manufacturing Company
P.O. Box 512
Rocky Ford, CO 81067
Telephone: (719) 254-7813
Fax: (719) 254-6371
E-mail: oliver@ria.net

Visit us at:
www.thomasregister.com/olivermfgco

OliverTM

Innovate. Build. Repeat.

Oliver Manufacturing Company • 27151 Harris Road • La Junta, CO 81050 • (888) 254-7814

olivermanufacturing.com